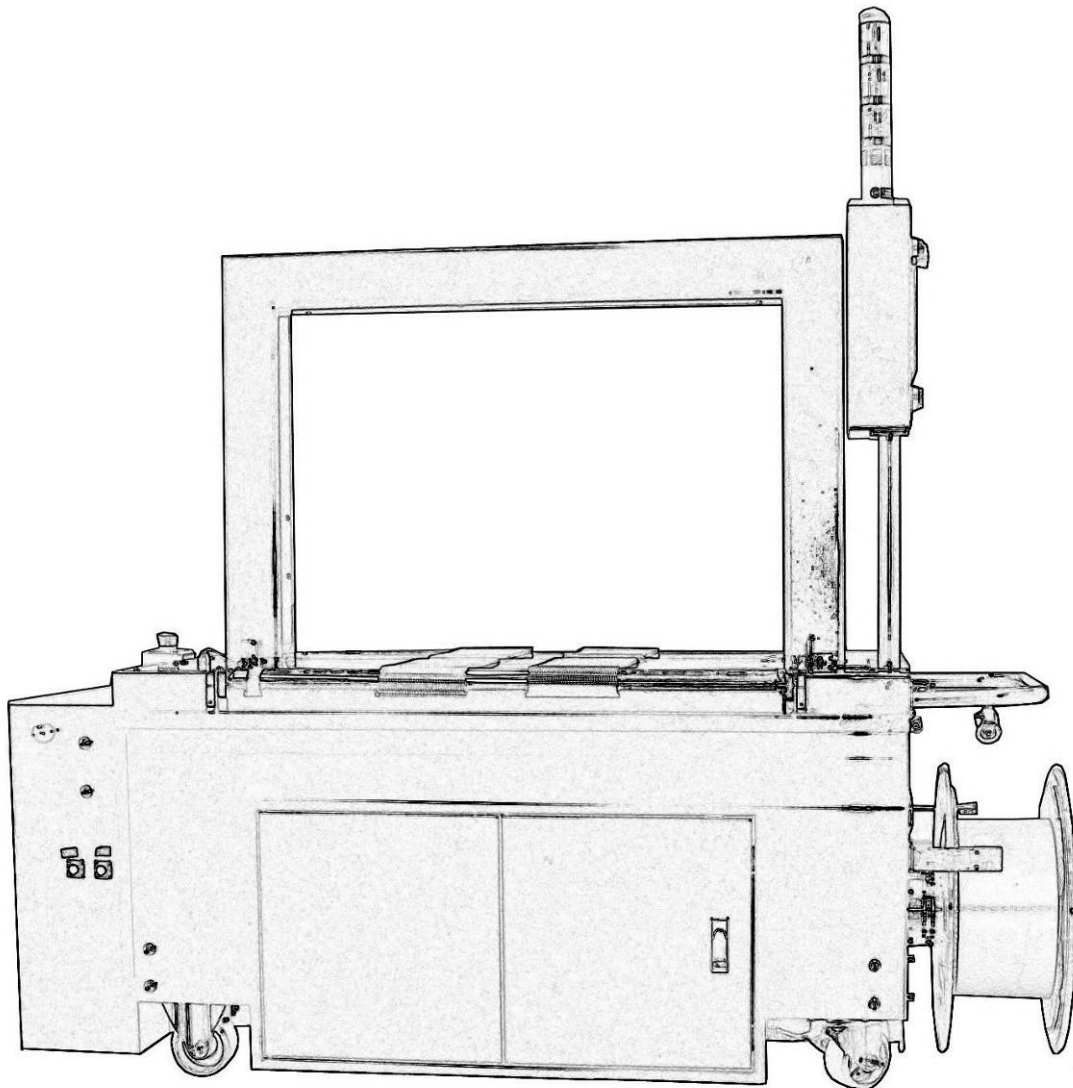


SV5000C

INSTRUCTION MANUAL FOR AUTOMATIC STRAPPING MACHINE



POLYCHEM Corporation

6277 Heisley Road, Mentor OH 44060.

TEL : 440-358-7060 FAX : 440-358-7061

Table Of Contents

Operation Manual		
Chapter 1: Safety Precautions		
1.1	Safety Warnings	4
1.2	Personal Safety Provisions	4
1.3	Mechanical Safety	5
1.4	Electrical Safety	6
1.5	Pneumatic Safety	6
1.6	Environment Safety	6
Chapter 2: Introduction		
2.1	Purpose Of The Strapping Machine	7
2.2	Purpose of This Manual	7
2.3	Technical Specifications	7
Chapter 3: Operating Instructions		
3.1	Introduction	9
3.2	Operator Controls And Indicators	10
3.3	HMI system	13
3.4	Starting The Strapping Machine	17
3.5	Loading The Strap	17
3.6	Manual Operation	18
3.7	Automatic Operation	18
3.8	Unloading The Strap	18
3.9	Shutdown	18
Maintenance Manual		
Chapter 4: Adjustments		
4.1	General Safety Precautions	19
4.1.1	Safety Warnings	19
4.1.2	Personal Safety Provisions	19
4.2	Home Position Switch Adjustment	20
4.3	Feed Stop Switch Adjustment	20
4.4	Feed Re-tracking Pinch Force Adjustment	20
4.5	Second Tension Pinch Wheel Adjustment	21
4.6	Accumulator Feeding Roller Proximity Switch	21
4.7	Accumulator Fill Proximity Switch Adjustment	21
4.8	Accumulator Fill Volume Adjustment	22
4.9	Accumulator Fill Force Adjustment	22
4.10	Strapping Height Adjustment	22
4.11	Strap Width Adjustment	23
4.12	Feed Roller Gap Adjustment	23
4.13	Heater Temperature Adjustment	23
4.14	Track Opener Wiring Adjustment	24
4.15	Cutter Block Cleaning And Adjustment	24
4.16	Strap Sealing Alignment Adjustment	24
4.17	Table Belt Adjustment	25
Chapter 5: Preventive Maintenance		
5.1	General Safety Instructions	26
5.1.1	Safety Warnings	26
5.2	Lockout Tag out Procedure	26
5.3	Pneumatic Safety (if equipped)	27
5.4	Maintenance Required After Each 15,000 cycles	27
5.5	Maintenance Required After Each 150,000	28
5.6	Maintenance Required After Each 300,000	28
5.7	Maintenance Required After Each 500,000	29
5.8	Maintenance for Applying Bearing Grease	29
Chapter 6: Trouble Shooting		
6	Trouble Shooting	30
Chapter 7: Safety During Installation		
7.1	Introduction	34
7.2	Safety Warning	34
7.3	Personal Safety Provision	35
7.4	Mechanical Safety	35
7.5	Electrical Safety	35
7.6	Pneumatic Safety (If So Equipped)	36
7.7	General Product Information	36
7.8	Installing The Strapping Machine	36
Chapter 8: Safety During De-Installation		
8.1	Introduction	37
8.2	General Product Information	37
8.3	Cleaning The Strapping Machine	37
8.4	Electrical shutdown of the strapping machine	37

Table Of Contents


Chapter 9:Part List And Drawings		9.7 Belt Driving Table Top Assembly	98
9.1 Control Unit	38	Fig-1K-AB: Belt Driving Table Top	98
Fig-1A: Cam Unit	38	Fig-2K-AB: Belt Driving Table Top	100
Fig-1B-AB: Slide Table Unit	41		
Fig-2B-AB: Slide Table Unit	44	9.8 Pneumatic Assembly	103
Fig-3B: Slide Table Unit	47	Fig-1L-AB: Pneumatic Assembly	103
Fig-4B: Slide Table Unit	49		
		9.9 Screw Specification List	106
9.2 Cam Unit	52		
Fig-1C: Roller Block Unit	52	9.10 Appendix A: motor application phase	108
Fig-3C-AB: Roller Block Unit	54		
Fig-4C-AB: Roller Block Unit	57	Chapter 10:Electrical Schematics	
Fig-1D-AB: Roller Block Unit	59	10.1 Wiring Schematic	110
Fig-2D: Roller Block Unit	62		
9.3 Accumulator Unit	64		
Fig-2E: Pool Unit	64		
Fig-3E: Accumulator	66		
Fig-4E: Accumulator Box	69		
Fig-5E-AB: Accumulator Box	71		
9.4 Arch Unit	74		
Fig-1F-AB: Arch Unit	74		
Fig-2F: Arch Unit	76		
Fig-1G: Arch Unit	79		
Fig-2G-AB: Arch Unit	82		
9.5 Body Unit	86		
Fig-6H-AB: Body Unit	86		
Fig-7H-AB: Body Unit	89		
Fig-8H-AB: Body Unit	91		
Fig-9H-AB: Body Unit	93		
9.6 Control Box Unit	95		
Fig-2J-AB: Control Box Unit	95		

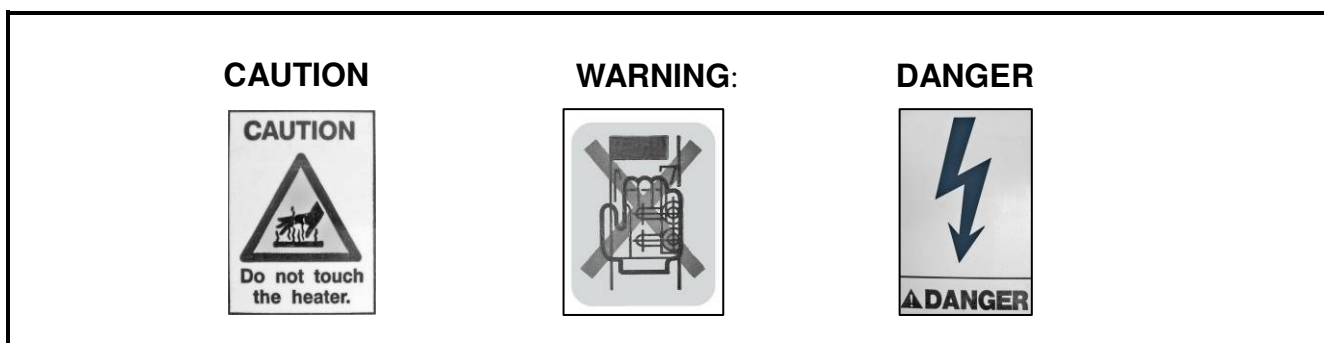
1

Safety Precautions

1.1


Safety Warnings

 Warning labels can be found in this manual and SV5000C machine. Indicate situations that require extra attention during installation, operation and maintenance of SV5000C. Observe the associated precautions carefully of indicated potential hazard.



1.2

Personal Safety Instructions

 The strapping machine has been designed to provide safe, efficient and trouble-free service for many years. However, as with any automatic machinery there is a risk of damage or injury if appropriate precautions are not taken.

You must read and understand the safety section and safety precautions in other sections of this manual before installation, operation, maintenance, or de-installation of the strapping machine. Section 1 Safety precautions, details inherent risks and general safety consideration associated with the operation and maintenance of this machine.

All operation and maintenance personnel must be trained by the manufacturer in the proper handling, operation, and maintenance of this machine. Failure to follow the precautions could result in equipment damage, personal injury, or loss of life.

The following safety instruction must be observed when using or working on the SV5000C.

- ✓ Read this operation manual before using the strapping machine.
- ✓ The operation manual should be attached to the machine all the time.
- ✓ Only trained personnel should operate the machine.
- ✓ Use protective equipment when machine running.
- ✓ Always disconnect the power supply when moving machine.
- ✓ Do not put any part of your body in bundle operating when machine is running.
- ✓ Do not put any part and tool onto the machine.
- ✓ Machine is only to be operated when it is in good condition.
- ✓ All safety and productive devices must be in place and fully functional.
- ✓ Check machine is fully safe before operation.

- ✓ All maintenance work and repairs have to through trained technician or engineer.
- ✓ Keep machine in dry condition.

1.3

Mechanical safety

*The following safety precautions **must be observed** when using or working on the machine.*

1. Keep working area safety and clean before operating.
2. Work on or operate the machine only in good status and make sure that safety switch or emergency stop can be operated in normal.
3. If machine malfunction, please had the machine repaired by the trained and experienced engineers.
4. Before doing the maintenance or moving the machine, make sure to disconnect the power supply first.
5. Make sure to tighten all contact or connection after performing the maintenance.
6. Appropriate footwear is required when moving the strapping machine.
When using a lift or forklift, make sure work with adequate capacity.
7. The using of suitable eye and ear protection is required while operating the machine or performing the maintenance.
8. Keep body and clothing out of the strapping position, arch and dispenser while running the machine.
9. Don't put unnecessary parts, tools, food or drinks on the table top.
10. Don't try to stand or sit on the table top.
 - See Section 3, [OPERATING INSTRUCTIONS](#), Section 4, [ADJUSTMENTS](#), Section 5, [PREVENTIVE MAINTENANCE](#), Section 7 [SAFETY DURING INSTALLATION](#), and Section 8 [SAFETY DURING DE-INSTALLATION](#) for additional safety information..

1.4

Electrical safety

The following safety precautions **must be observed** when using or working on the machine.

1. Strapping machine need to be grounded to avoid the risk of electric shock.
Single phase machine is equipped with an electric plug including green earth (E).
Three phase machine is equipped with a cord including green earth wire (with yellow wire for CE), make sure the electric plug or green earth wire all connect to the grounded socket or breaker to meet local electrical regulation
2. Before turning on the power, make sure the machine configured for the right phase and voltage.
3. If something wrong in the control system, please turn the power off first.
4. Only experienced and qualified electricians can perform on the electric works.
5. Regular inspect and make sure tighten all contacts and wires after doing the maintenance.
6. **DO NOT** attempt to remove the safety switches.

1.6

Pneumatic Safety

The following safety precautions must be observed when using or working on the SV5000C

1. Do not exceed the maximum operating pressure of the SV5000C
2. Inspect all connections, hoses, and fittings on a regular basis.
3. Periodically check the SV5000C pneumatic component operation.
4. Ensure all components are correctly assembled before applying air pressure.

1.7


Environment Safety

1. Environmental temperature 0~50°C.
2. Environmental humidity 20%~85% RH.
3. Operation under high pollution environment, such as flying dust, salt and caustic gas, should be avoided.
4. Avoid working in a dim light. Providing sufficient light is necessary.
5. Working place should equip with fire extinguisher.
6. Don't expose the machine in rain or damp environment.
7. The exhaust system shall be installed in order to prevent possible harmful gases, fumes or dust generated during heating.


2

Introduction

2.1 Purpose of the strapping machine

 The strapping machine has been designed to strap individual bundle with PP strapping. The strap is automatically applied around the bundle, securely heat sealed, and severed from the strap supply. See STRAPPING MACHINE TECHNICAL SPECIFICATIONS in section 2.3 for performance parameters and specifications for the strapping machine. Use of the strapping machine, for any purpose other than described in this publication or expressly approved by the manufacturer prior to implementation should be avoided. The strapping machine must be shut down for all maintenance procedures for which operation is not required.


2.2 Purpose Of This Manual

 The purpose of this manual is to:

1. Explain the operating principles.
2. Outline the maintenance and operating procedures.
3. Detail recommended adjustments of the strapping machine.

Figures are included in the text illustrating the general arrangement and identifying major components. A more breakdown of the strapping machine will be found in drawings of each major assembly as well as a complete parts list.

2.3 Technical Specifications

 MACHINE WEIGHT:	440 lbs / 200 kg
CURRENT:	220V~490V (210/220/230/240/440/460/480/490) 3
STRAP WIDTH:	5mm, 6mm, 9mm.
STRAP THICKNESS:	0.40mm ~ 0.8mm
STRAP MATERIAL:	Polypropylene.
CYCLE SPEED:	up to 52 straps per minutes (Depending on arch size and package size).
Maximum bundle weight:	110 lbs (50 kg)
MINIMUM BUNDLE SIZE:	Height: 4mm / 1/8 inch. , Width: 250mm / 10 inch.
LENGTH:	100mm / 4 inch.
POWER CONSUMPTION:	0.7 kw

ATTN: 5,6,9mm strap width can be changed by optional accessory but 12mm should be specified from manufacturer due to different track system.


The exhaust system shall be installed in order to prevent possible harmful gases, fumes or dust generated during heating. For the extraction of harmful substances, the exhaust system shall be positioned at the vent circulating location.

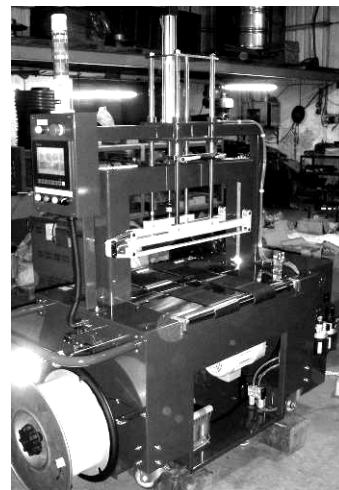
3

Operating Instructions

3.1

Introduction

 The strapping machine is designed for manual or automatic strapping operation. All the operation, adjustment, maintenance of strapping machine must be carried out by trained and authorized personnel.



Transportation

The equipment is delivered in transport units. Each transport unit is loaded onto a wooden pallet, secured by Polypropylene strapping, covered with a carton box for protection. Lift the unit using forklift truck or other lifting device. The machine can be removed from the pallet by using forklift truck or other lifting device.

CAUTION:

Do not carry machine by having the forklift's fork under the arch, but only under the machine frame. Inappropriate mounting the load can cause serious injuries or death.



Installation

Remove the packing material and check that the machine is complete and without any shipping damage. DO NOT move the machine unless it is necessary. Before the movement, be sure to turn off the power.

3.2

Operator controls and indicators

 Auto Feed ON/OFF Switch:

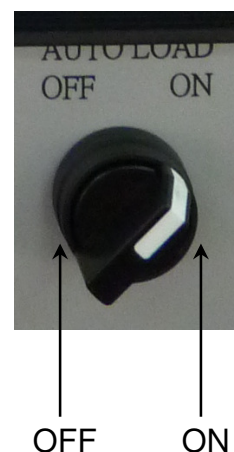
Turn the switch to “OFF” :

The brake of the dispenser is released. The dispenser can be turned freely so that strap can be fed manually through the accumulator’s feeding rollers.

Turn the switch to “ON” :

Before switching to auto-feed mode, make sure that strap is properly inserted within the accumulator’s feeding rollers.

Select ‘Off mode to manually feed the strap into the accumulator’s feed rollers. Turn switch to “On” to perform auto loading, and the strap is fed into the accumulator and then filled through the arch.



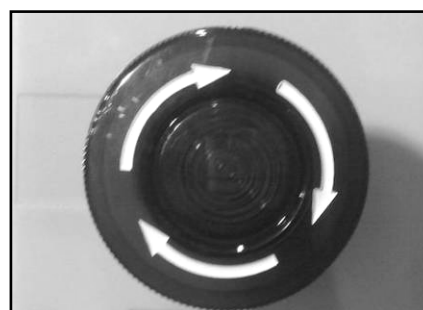
 POWER ON-OFF Switch :

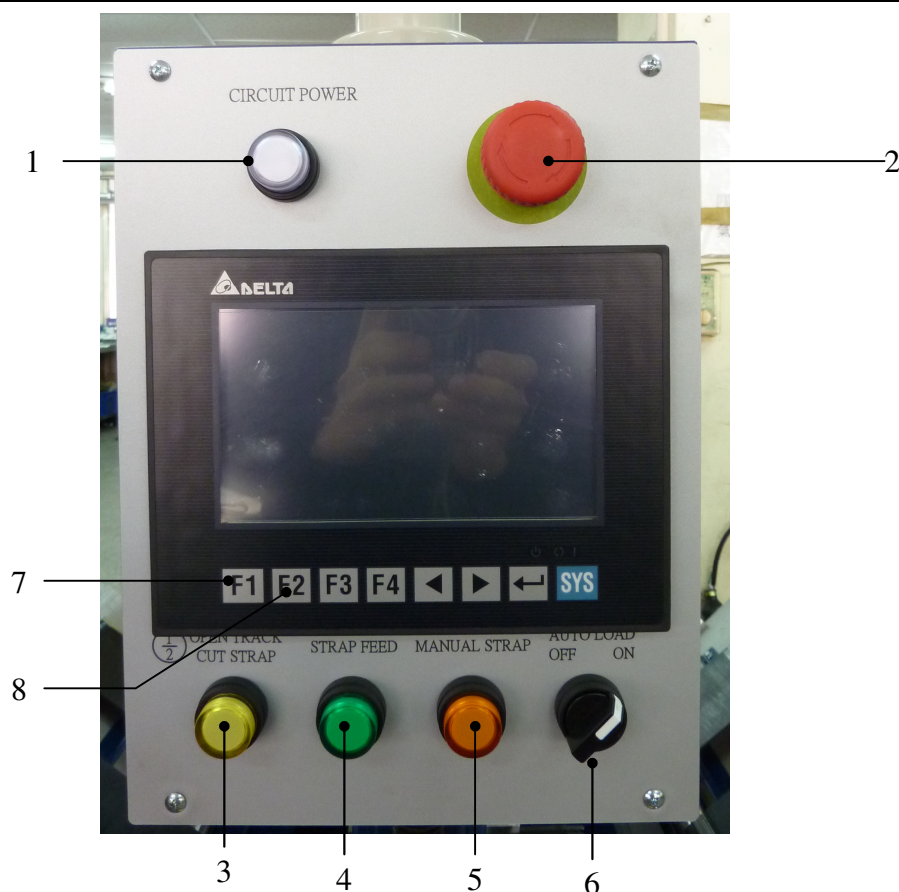
The main power ON-OFF switch, which controls the main electrical power to the strapping machine. The front door can only be opened when the switch is on OFF position.



 Emergency Stop Push Button :

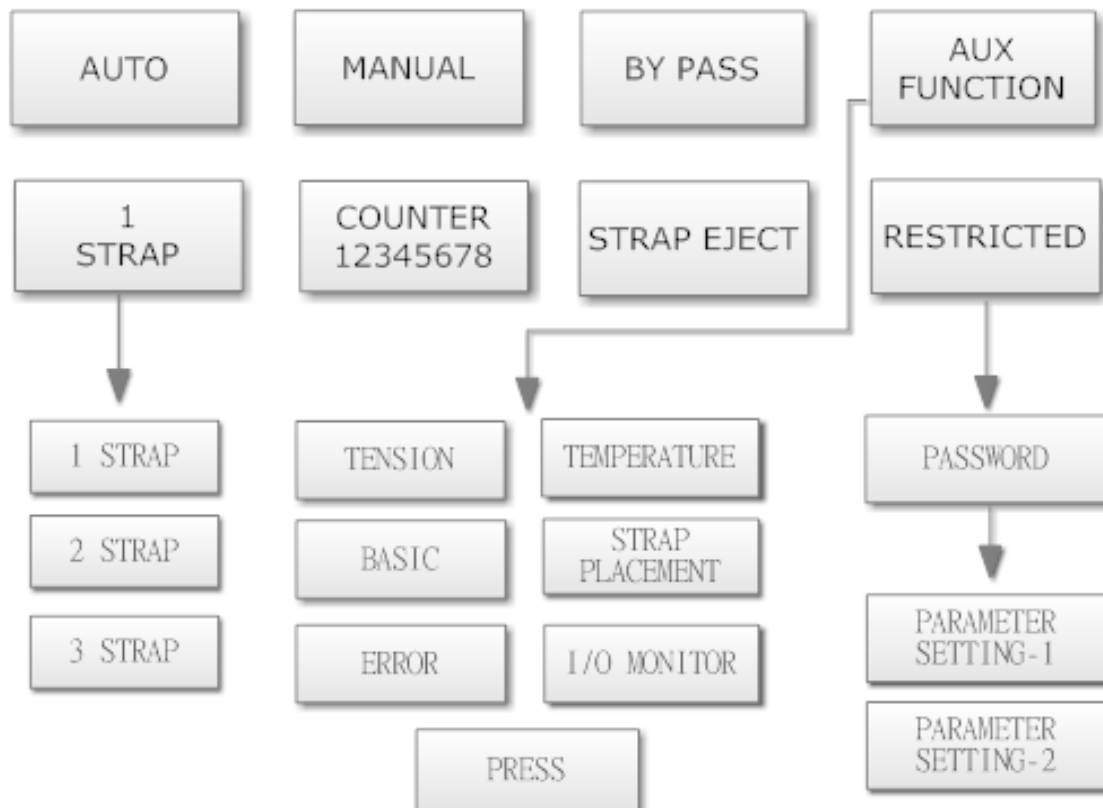
This push button is to stop the machine immediately but the power remains. It is a push-pull twist to release the button. To restart the machine, pull or twist clockwise to release the emergency stop push button and press the circuit power button to retrieve the power.





1. **Circuit power:** to start the machine when the main power is switched on and emergency stop is released. Push the circuit power switch to start the equipment. It will be illuminated after started. Then heater is on.
2. **Emergency stop (E-Stop):** push the E-Stop button to stop the operation of this machine. Motors and heater would be off and then red alarm light is illuminated. To restart, release E-stop button by turning the E-stop clockwise then push the circuit power button.
3. **Open track / cut strap:** in case of miss-feed, push the button to open the track. Push the button again to cut strap. Yellow light would be illuminated.
4. **Strap feed:** if strap is not fed to sealing position, push the button to feed strap. Green light would be illuminated. If the strap is still no to sealing position, green light would flash.
5. **Manual strap:** to operate under manual mode. Push “Manual” button on HMI. Manual mode – orange light flashing. Auto mode – orange light illuminates.
6. **Auto load On/Off:** OFF - release dispenser brake. ON – starts to feed in the strap automatically
7. **F1 push button:** to push the button back to welcome page.
8. **F2 push button:** Press F2, enter into PLC INPUT/OUTPUT status display.

Welcome page



3.3

HMI system

1. Welcome page:

Welcome page show after power on, touch any place in the screen then enter to BASIC screen.



F-1

2. BASIC page:

2.1 AUTO

2.2 MANUAL

2.3 STRAP NUMBER

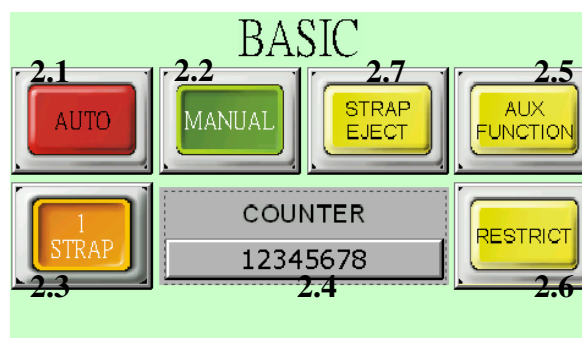
Touch the button to select the number of strap

1 STRAP – apply one strap in one bundle

2 STRAP – apply two straps in one bundle

3 STRAP – apply three straps in one bundle

BY PASS –press this button then the conveyor table top is only driving without strapping.

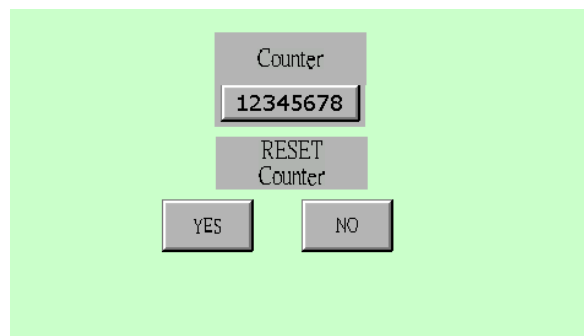


F-2

2.4 COUNTER

The button displays the number of straps that the strapping machine has applied.

To reset counter, touch the Counter button (FIG-2) and the screen (FIG-3) appears. Select YES to reset the number of the counter.





F-3

2.5 AUX FUNCTION


Press AUX FUNCTION button and enter the adjustment page (FIG-4).


Tension:

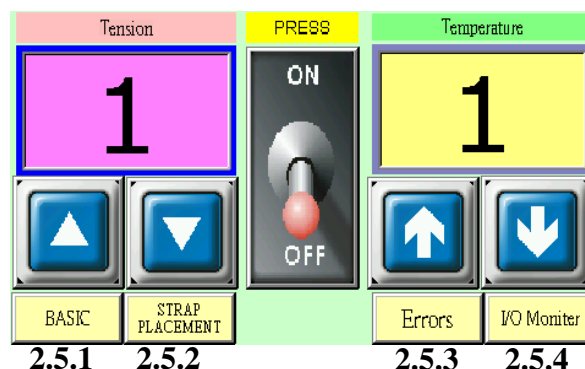
Touch  to increase the strapping tension

Touch  to reduce the strapping tension

Temperature of heater:

Touch  to increase the temperature of heater

Touch  to reduce the temperature of heater



F-4

Press:

Select 'ON' to activate the pneumatic unit

Select 'OFF' to stop the pneumatic unit.

2.5.1 BASIC

Press this button to go back to Basic Page

2.5.2 STRAP PLACEMENT (FIG-5)

D30-1st strap position

D31-2nd strap position

D32-3rd strap position

D37-Cylinder OFF – delay time after cylinder hits the package

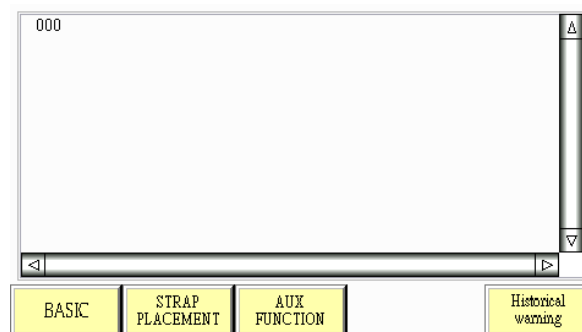
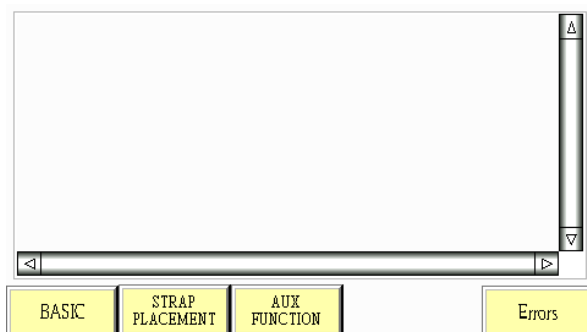
D38-Auto Feeding Time –controls feed roller activation time. The larger value, the longer feeding time.

Number	Description	Ex Work Set	Present Set
D30	1st strap position	1.00	##.##
D31	2nd strap position	1.00	##.##
D32	3rd strap position	1.00	##.##
D37	Cylinder OFF	1.00	##.##
D38	Auto Feeding Time	1.00	##.##

F-5

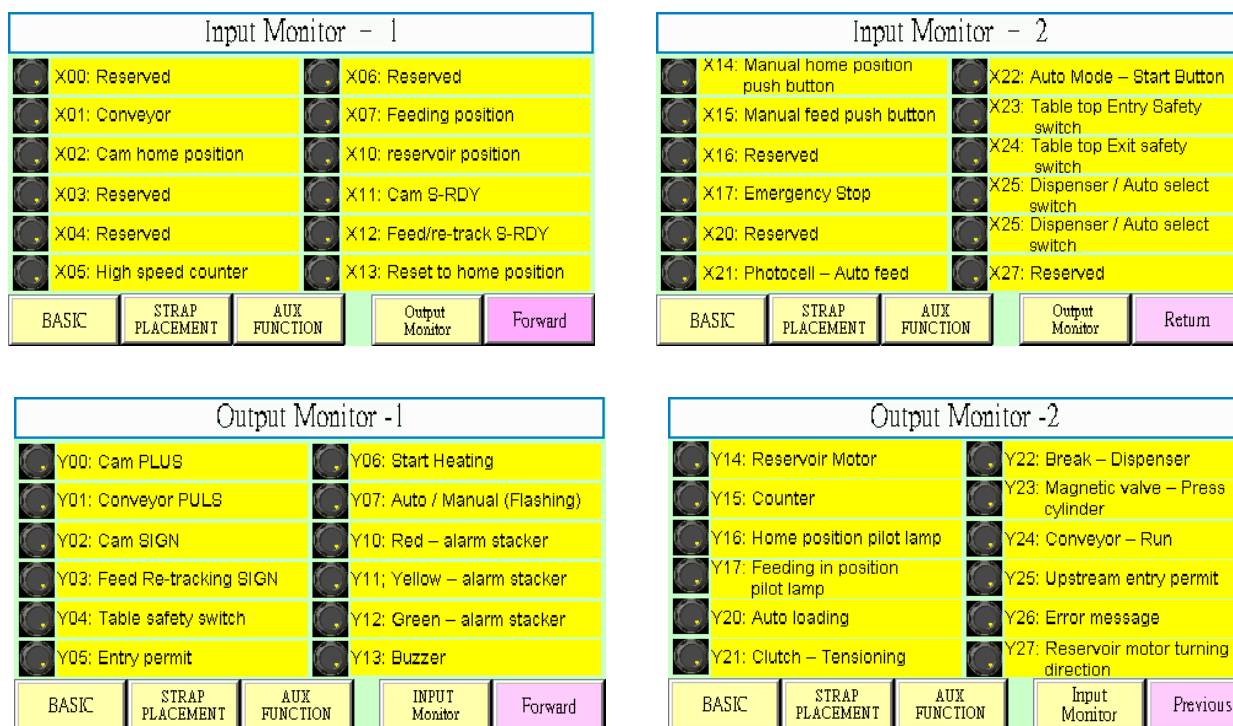
2.5.3 Error (FIG-6)

This page displays the error logs of the strapping machine.



F-6

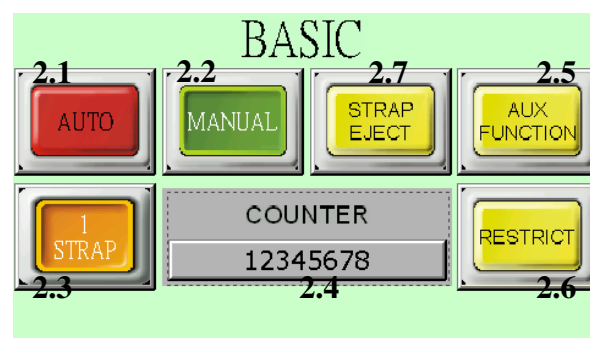
2.5.4 I/O Monitor (FIG-7)



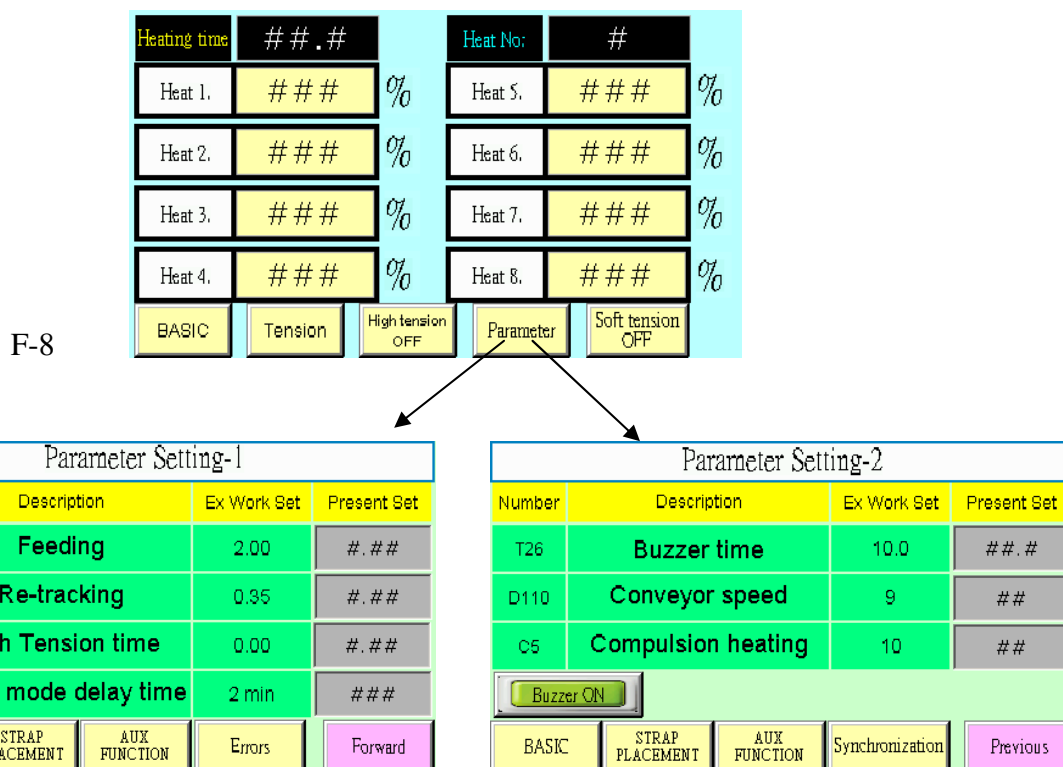
F-7

2.6 RESTRICTED button (FIG-2):

To adjust all parameter settings (FIG-8) from PLC for engineer or maintenance such as Feeding, re-tracking, High tension time, Sleep mode delay time, buzzer time, conveyor speed, complusion heating time, Buzz on/off.



F-2



T190-Sleep mode delay time: pre-set as 2 mins. After the certain amount of time without any new strapping signals (applying straps, reset...etc), the machine will stop its table belt transit and turn on sleep mode.

C5-Compulsion heating time: after certain number of straps (set by this value), heater blade would be heated up again compulsorily for maintaining the strapping performance.

2.7 Strap Eject button (FIG-2):

Press this button to remove all PP strap from accumulator and arch. The strap will be ejected from the strap inlet.

3.4

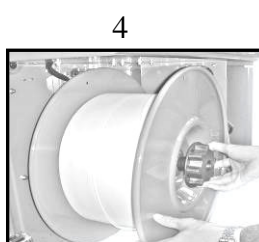
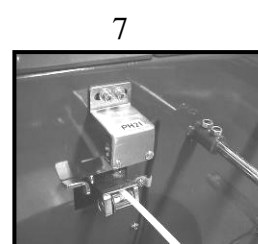
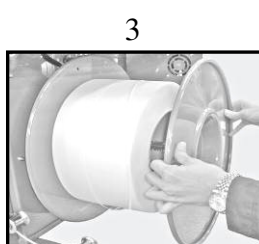
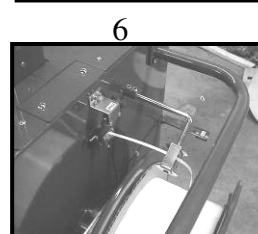
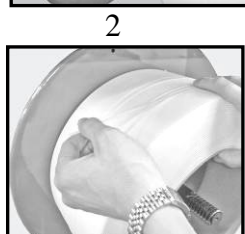
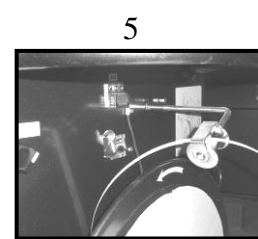
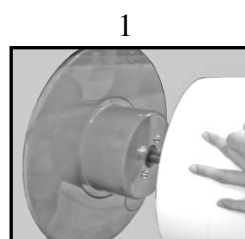
Starting the strapping machine

1. Ensure the electrical power supply and compressed air supply are properly connected to the strapping machine (see 2.3 Strapping Machine Technical Specifications)
2. Ensure all doors and top plates are closed and latched.
3. Ensure the Emergency Stop push button is pulled and released.
4. Rotate the ON-OFF switch clockwise so it is in the ON position with a “1” visible in the switch position indicator slot.
5. Press the Start/Strap push button once. It will illuminate to indicate the machine has been started.
6. Approximate 1 minute for loading the program and rising the temperature of the heater blade.

3.5


Loading the strap

1. Turn on the strapping machine. Turn the select AUTO FEED switch to “OFF”.
2. Release the reel nut handle and remove the outer flange plate. Place a strap coil on the reel drum according to the arrow direction indicated on the reel out circular. Put back the flange plate and re-tighten the reel nut handle.
3. Make sure the end of the strap is even.
4. Thread the strap under the strap exhaust switch, and through the accumulator’s feeding roller.
5. Turn AUTO FEED to “ON” to start loading. PP Strap will be filled through the accumulator and the arch automatically. The start button illuminates when the strapping machine is ready for strapping.




3.6

Manual operation

- 
1. Turn on the strapping machine and ensure the E-stop released, all door and safety interlock are ready for operation.
 2. Ensure the accumulator and track have been filled with strap.
 3. Set the Manual/Auto under Manual mode. And the light of manual strap is flashed
 4. Position a package under the arch, on the top plate. To strap the package, press the Start Strap push button. Once push the start button then it keep continuing strapping till released from the start button.

3.7


Automatic operation

- 
1. Turn on the strapping machine and ensure door closed and table top latched.
 2. Ensure the accumulator and track have filled with strap.
 3. Set the Manual/Auto under Auto mode. Circuit power and strap feed illuminated.
 4. Select single or double strapping or pass.
 5. Conveyors starts then the equipment perform the automatic strapping.

Attention! KEEPS HANDS AWAY FROM THE STRAPPING AREA. *If hands are caught by PP strap accidentally or incident happens, push the E-stop button to stop all the operation, and then cut the strap.*


3.8

Unloading the strap

- 
1. Turn on the machine and ensure that strap is loaded in the machine. Press the 'strap eject' button on HMI screen to eject all strap in the arch and accumulator.
 2. Take outer flange out of coil dispenser.
 3. Take strap coil from dispenser. Then put the flange back to the dispenser.

3.9

Shutdown

- 
1. Eject the strap from machine.
 2. Turn the ON/OFF power switch to the OFF position. An "O" should be visible in the indicator of panel.

4

Adjustments

4.1 General Safety Precautions

☞ Carefully read Section 1, Safety precautions, before making any adjustments to the strapping machine. The safety section details inherent risks and general safety considerations associated with the operation of the strapping machine. Failure to follow these instructions could result in equipment damage, personal injury and/or death.

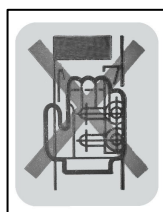
4.1.1 Safety Warnings

☞ Warning labels that correspond with warning labels on the strapping machine are used throughout this manual. The signal situations that are required extra attention during machine installation, operation, or maintenance. Observe the associate precautions carefully as they indicate a potentially hazardous situation.

CAUTION



WARNING:



DANGER



4.1.2 Personal Safety Provisions

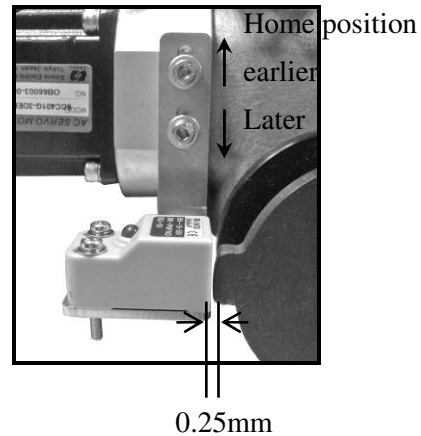
☞ The operation of strapping machine is fully automatic. Any inattention while close to the strapping machine could result in personal injury or equipment damage. Precautions must be taken to avoid material being automatically conveyed to the strapping machine when it is out of service. Shut down the strapping machine does not necessary prevent other equipment in the line from operating.

For all maintenance activities not requiring the strapping machine to be in operation, a lockout, tagout procedure applies, see Preventive maintenance. All personnel working on or around the strapping machine during installation must be qualified for their position.

4.2

Home Position Switch Adjustment

☞ Measure the gap from the switch to the face of cam. It should be 0.25mm. If the gap varies from this distance, adjust the switch by loosening the cross recessed screw, move the proximity switch upward or downward.



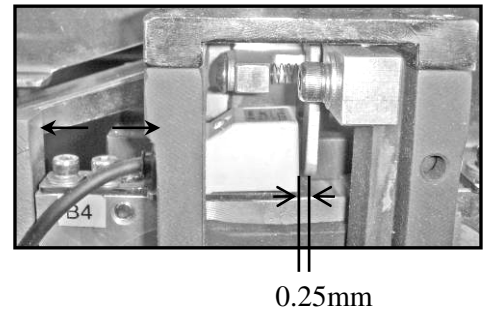
4.3

Feed Stop Switch Adjustment

☞ 4.3.1 Move the 'feed stop switch lever' to be close to the switch

☞ 4.3.2 The gap between switch and lever should be 0.25mm. (refer to the photo)

☞ 4.3.3 If the lever and the switch do not line up, loosen switch locknut, move proximity switch, and re-tighten.



4.4

Feed / re-tracking pinch force Adjustment

☞ To set the force of Feed/Re-tracking roller, loosen the left nut first and adjust the right nut to change the tension of the spring.

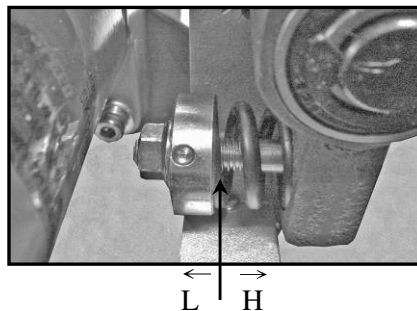
Increase the force of feed/re-tracking roller:
Tighten the right nut to move the hexagon screw to the right, which adds the tension on the spring.

Decrease the force of feed/re-tracking roller:
Loosen the right nut to move the hexagon screw to the left, which leaves the tension on the spring.



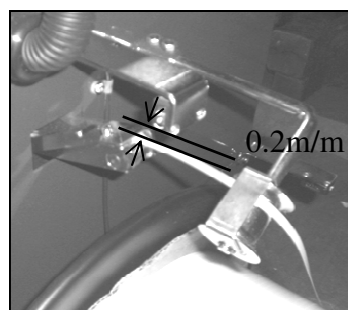
4.5 Second tension pinch wheel adjustment

☞ The second tension roller pinch force to be adjusted through the spring force as illustrated on the picture. To secure higher pinch force, please turn the stop nut clockwise then re-tighten locknut. The higher compression force is for higher pinch force on main roller.



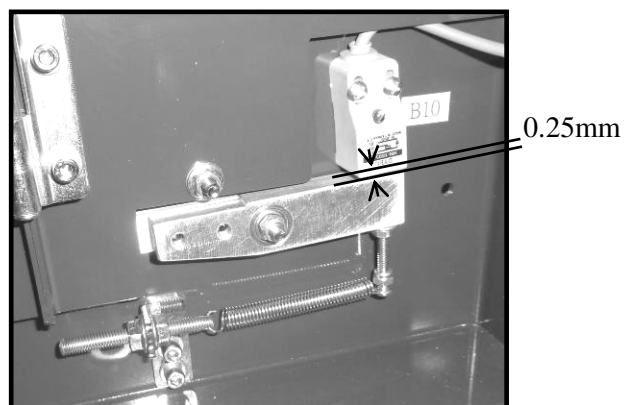
4.6 Accumulator feeding roller proximity switch

☞ The accumulator feeding roller sensor saves whether the strap is in feeding roller or not. Make sure the sensor is activated when strap is there. The gap is 0.2m/m.



4.7 Accumulator fill proximity switch adjustment

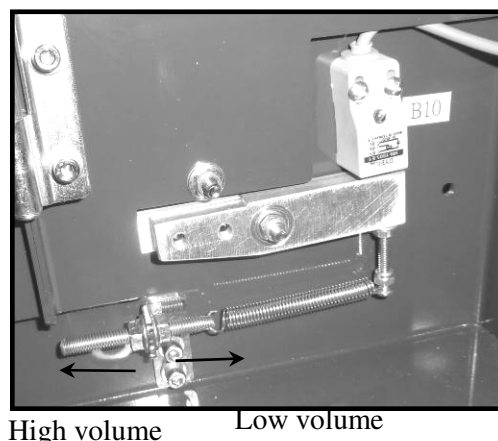
☞ The accumulator wand goes down and activates the accumulator fill proximity switch when there is and adequate strap supply in the accumulator. To adjust the proximity switch, loosen the two nuts, adjust the switch as shown for proper operation, and then re-tighten the nuts (Figure).



4.8 Accumulator fill volume adjustment

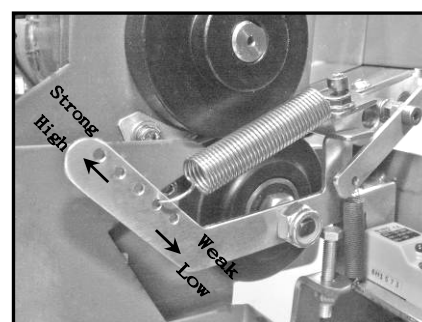
☞ To adjust the strap volume to the desired amount of strap, loosen or tighten the tension on the wand spring by adjusting the length of the spring mounting screw.

To reduce the amount of strap in the accumulator, spin the jam nuts on the mounting screw counterclockwise. To increase the amount of strap in the accumulator, spin the lock nuts in a clockwise direction.



4.9 Accumulator Fill Force Adjustment

☞ The different hook position is designed for adjusting the pinch force of accumulator feeding pinch force, the higher position for high pinch, vice versa.

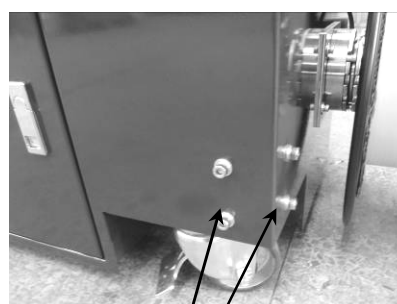


4.10 Strapping Height Adjustment

☞ WARNING: USE FORKLIFT IN A SAFE AND APPROPRIATE MANNER. ENSURE THAT ALL LIFTING OF THE STRAPPING MACHINE IS DONE IN A SAFE AND RESPONSIBLE MANNER. FALLING OBJECTS ARE A LIFE THREATENING HAZARD.

To adjust the height of the machine, first support the weight of the machine and loosen the two hex-head bolts on each leg of the machine. Lift the machine until the top plated are at the desired working height. Then release the tension on the retaining bolts and slide the legs to the floor. Tighten the retaining bolts to retain position.

WARNING: DON NOT LOOSENS THE LEG BOLTS PRIOR TO SUPPORTING THE MACHINE WEIGHT.




Loose the four hex-head bolts

Lift the machine until the top plated are at the desired working height

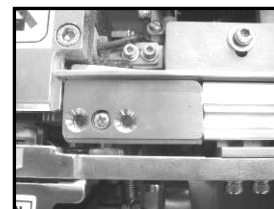
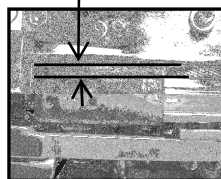
4.11

Strap Width Adjustment

 To adjust the left strap guide and right strap guide as following;

- (a). To release the two screw, and take out the strap guide cover.
- (b). release the screw then adjust the strap path width about strap width + 1mm.

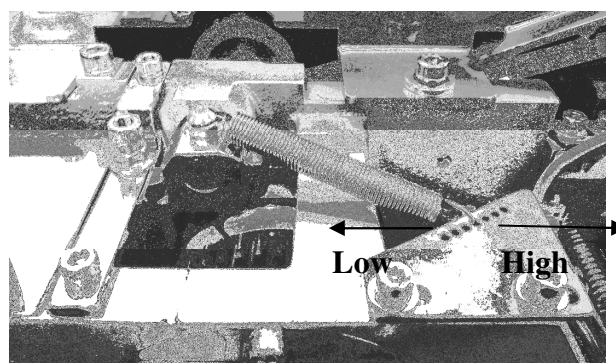
Strap width +0.5mm



4.12

Feeding roller gap adjustment

Adjust the feeding pinch force by moving the spring hook position, the higher k value for higher pinch force. Vice versa.



4.13

Heater temperature adjustment

 **Heater temperature**

Heater's temperature is monitored all the time. The temperature controlling system would heat up or off to keep the heater temperature kept as preset value. The machine is set at 190°C for 5mm strap, 280°C for 12mm strap.

 **Tension**

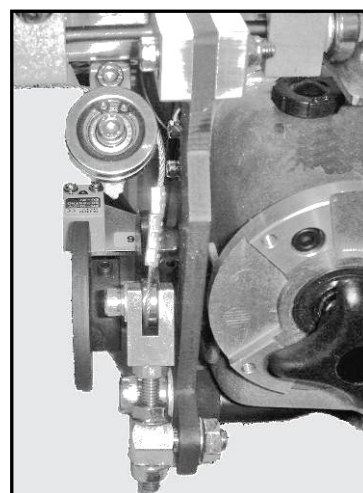
The tension is decided by the second retracting time. Operator may adjust the tension according to the needs.

 **Weld cooling**

Under higher strapping tension requirements, the machine should be adjusted to higher cooling time. The higher tension is set, the longer cooling time is required.

4.14 Track opener wiring Adjustment

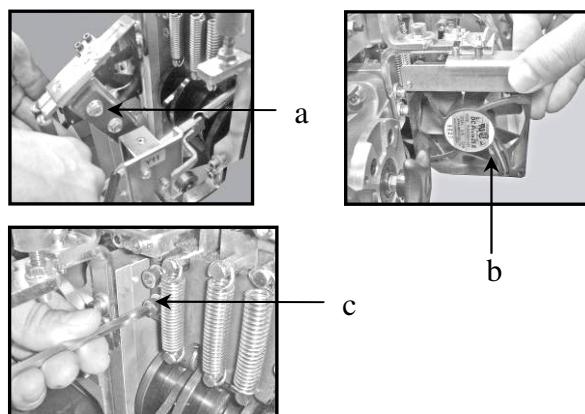
☞ The arch opening can be adjusted by setting the screw as shown in the picture. To adjust the wire, loosen the two nuts, adjust the wire as shown on proper position and then re-tighten the nuts. Be aware that wire must be the original parts supplied by Joinpack, different unauthorized parts may create problems. To make sure the adjustment is proper, turn jog nuts to see if the arch chute is well closed against the side cover plate.



4.15 Cutter Block cleaning and Adjustment

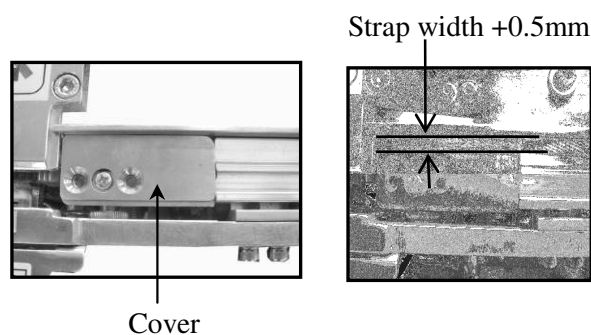
☞ The cutting block is allowed to be taken out for maintenance. The step of taking out cutter block as following:

- (a). Release the spring in the heater arm.
- (b). Release the wing nut of exhaust fan.
- (c). Release four hexagon screws.
- (d). Taking out the whole cutting block.




4.16 Strap Sealing Alignment Adjustment

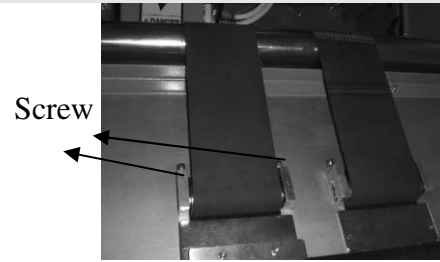
☞ To take off the strap guide cover by loosening 2 screws as shown on fig. xx, to adjust the side plate to fit the strap width, the strap width + 0.5mm to be set for strap guide width.



4.17

Table Belt Adjustment


 To loosen or tighten the screw to adjust the tension of belt.



5


Preventive Maintenance

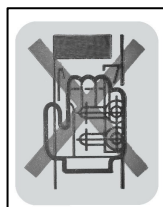
5.1 General Safety Instructions

 The strapping machine has been designed to provide safe, efficient and trouble-free service for many years. However, as with any automatic machinery there is a risk of damage or injury if appropriate precautions are not taken. You must read and understand the safety section and safety precautions in other sections of this manual before installation, operation, maintenance, or de-installation of the strapping machine.


Section 1 Safety precautions, details inherent risks and general safety considerations associated with the operation and maintenance of this machine. Failure to follow these precautions could result in equipment damage, personal injury, or loss of life. All operation and maintenance personnel must be trained by the manufacturer in the proper handling, operation, and maintenance of this machine.

5.1.1 Safety Warnings


 Warning labels found in this manual and on the strapping machine indicate situation that require extra attention during strapping machine installation, operation, maintenance, or de-installation. Observe the associated precautions carefully as they indicate potentially hazardous situations.

CAUTION**WARNING:****DANGER**

5.2 Lockout Tag out Procedure

 The strapping machine is an automatic machine. Any inattention while close to the strapping machine could result in a mishap. Precautions must be taken to avoid material being automatically conveyed to the strapping machine when it is not in service. Shutting down the strapping machine does not necessary prevent other equipment in the line from operating.

For all maintenance activities not explicitly requiring the strapping machine to be in operating, a lockout tagout procedure applies. All personnel working on or around the strapping machine during installation must be qualified for their position. All local laws and facility specified lockout tagout requirements that meet or exceed this procedure must be strictly adhered to.

 5.2.1.1 Ensure no product can be conveyed into the strapping machine.

5.2.1.2 Press the red Emergency Stop push button.


5.2.1.3 Turn the ON/OFF switch to the OFF position.

5.2.1.4 Lock the ON/OFF switch on the OFF position.

5.2.1.5 Tag the pendant with a sign: Maintenance Activities in Progress


To re-establish the normal strapping machine operation, reverse the lockout tagout procedure, and follow the instructions as shown in Section 3, Operation Instructions.

5.3 Pneumatic Safety (If so equipped)

 The following safety precautions must be observed when operating or doing maintenance :


1. DO NOT exceed the maximum operating pressure of the strapping machine.
2. DO NOT stand, sit or lie on the strapping machine.
3. Inspect all connections, hoses and fittings on a regular basis.
4. Periodically check strapping machine pneumatic component operation (if equipped).

5.4 Maintenance required after each 15,000 straps




Maintenance Item	Maintenance activity	Safety Warning
1.Blow out machine 2.Apply bearing grease	1.Blow the strap dust and other debris off of the interior and exterior of the machine at the end of every 15,000 straps. 2.Apply “SKF bearing grease” (LGHP 2/1, high performance polyurea) onto front gripper, press bar, and rear gripper.	Caution: Do not use the air hose to clean anything other than the machine. Caution: Flying debris can cause injury to the eyes and noise can result in hearing loss. Wear eye and hearing protection at all times.

5.5 Maintenance required after each 150,000 straps

Maintenance Item	Maintenance activity	Safety Warning
 <ol style="list-style-type: none"> 1. Blowing down internal portion of sealing head 2. Visually check the machine for wear and general condition. 3. Apply bearing grease 	Blow out the sealing head with compressed air. Apply “SKF bearing grease” (LGHP 2/1, high performance polyurea) onto front gripper, press bar, and rear gripper.	<p>Caution: Be careful of pinch points when opening and closing doors and cover.</p> <p>Caution: Do not use air horse to clean anything other than the machine.</p> <p>Caution: Flying debris can cause injury to the eyes and noise can result in hearing loss. Wearing eye and hearing protection at all times.</p>

5.6 Maintenance required after each 300,000 straps

Maintenance Item	Maintenance activity	Safety Warning
 <ol style="list-style-type: none"> 1. Check heater blade temperature setting. 2. Check condition of clutch’s gap. 3. Check condition of all drive and conveyer belts 4. Check condition of all pneumatic (if is equipped) connections hoses and fittings. 5. Apply bearing grease 	Apply “SKF bearing grease” (LGHP 2/1, high performance polyurea) onto front gripper, press bar, and rear gripper.	<p>Caution: Be carefully of pinch point when opening and closing machine doors and cover. DO NOT touch the heater blade. A severe burn may result from contact.</p>

5.7 Maintenance required after each 500,000 straps



Maintenance Item	Maintenance activity	Safety Warning
1. Check adjustment of right hand gripper, height and force 2. Apply bearing grease	Apply “SKF bearing grease” (LGHP 2/1, high performance polyurea) onto front gripper, press bar, and rear gripper.	Caution: Be carefully of pinch point when opening and closing machine doors and cover. DO NOT touch the heater blade. A severe burn may result from contact.

5.8 Maintenance for Applying Bearing Grease

Grease spec:

GHP 2/1, high performance polyurea

Procedure:

Following the instruction of maintenance, regularly apply the grease onto front gripper, press bar, and rear gripper of sealing head unit. Paste bearing grease on the sides of bars/cutter, to ensure smooth movement of bars.

6




Trouble Shooting

Before troubleshooting, read Section 1 'Safety Precautions' and Section 5 'Preventative Maintenance' in the operation manual. Adjustments made to the strapping machine must be performed by trained and authorized personnel. Ensure the area is clear before restarting the machine. A maintenance log should be kept to track the machine's malfunctions. Recommend to record:

- ✓ The date of problem occurrence
- ✓ A description of the encountered problem
- ✓ Pertinent machine settings at the time of problem occurrence or machine settings that seem to result in a problem.
- ✓ Any corrective actions taken



If a pattern of mechanical problems becomes evident, please inform your dealer and provide recorded log information, photos, or videos.

The following troubleshooting chart is designed to assist maintenance personnel in the identification and correction of problems that may occur with the strapping machine. If problems persist or cannot be resolved, contact your dealer for further assistance.

Symptom	Probable cause	Remedy
 Machine not start	<ol style="list-style-type: none"> 1. Strapping machine not started properly. 2. Emergency stop push on. 3. Door with Safety key open. 	<ol style="list-style-type: none"> 1. Refer to starting the strapping machine. 2. Release the E-Stop button. 3. Close the Electrical control box's door.
 Strap not loaded	<ol style="list-style-type: none"> 1. Strap accumulator motor pinch rollers out of adjustment. 2. Strap feed idle roller interfering with strap guide cover. 3. Strap accumulator fill proximity sensor out of adjustment. 4. Machine configured for incorrect strap width. 	<ol style="list-style-type: none"> 1. Adjust the accumulator pinch force. (Section 4.6). 2. If feel the idle roller interfered, then move out the cover so it may freely turn. 3. Adjust feed proximity sensor. (Section 4.6.) 4. Change the strap according the instructions.
 Strap not feed around track	<ol style="list-style-type: none"> 1. Obstruction in feed path. 2. Track out of adjustment. 3. Feed wheel gap too wide. 4. Feed distance too short. 5. Idler wheel not rotating. 6. Lubrication or contamination 	<ol style="list-style-type: none"> 1. Hand feeding the strap through the track, remove the obstruction. Verify the sealing head is in the home position during the feed cycle. 2. Adjust the track (Section 4.16). Make sure the track is close against the side frame. And opening is wide enough. 3. Adjust the feed roller setting gap which should be 0.1mm. 4. Adjust the feeding time which to be set according to the adjustments. 5. Feed idle roller to be interfered with strap guide or guide cover. Eliminate those interferes. 6. Clean wheel surface.



6

Trouble Shooting

Symptom	Probable cause	Remedy
	7. Strap reservoir out of strap. 8. Strap is jammed – feed idle roller not rotating. 9. Strap is jammed – Strap guide cover loose. 10. Strap is jammed – obstruction in the strap auto loading path. 11. Strap feeding out of sealing head. 12. Pinch rollers are worn.	7. Check if the strap reservoir is empty. If so, adjust according to 4.8 fill volume. 8. Feed idle roller to be interfered with strap guide or guide cover. Eliminate those interferes. 9. Fasten the strap cover plate. 10. Hand feed the strap to find out the obstruction then remove it. 11. Adjust the home position. (See adjustment section 4.2). 12. Change roller.
 Strap not tension	1. Tension force not adequate. 2. Lubrication or contamination on wheels. 3. Strap is jammed – strap guide cover loose. 4. Primary tension pinch rollers are worn.	1. Adjust the tension force according to 4.14. 2. Clean wheel surface. 3. Fasten the strap cover plate. 4. Change roller.
 Poor or no seal	1. Heater blade temperature incorrect. 2. Heater blade mounting screws loose. 3. Platen press time too short. 4. Second tension set too high. 5. Poor strap seal alignment.	1. Set the temperature. (See adjustment 4.14). 2. Check screws and tighten if necessary. 3. Change the setting. (See section 4.14 weld cooling time). 4. Adjust the second tension. (See section 4.14). 5. See adjustment 4.19.

6

Trouble Shooting


Symptom	Probable cause	Remedy
	<p>Misalignment due to improper adjustment of the entry plate guide.</p> <p>6. Heater bus bar dirty.</p>	<p>See adjustment 4.19.</p> <p>6. Clean the bus bar.</p>
<p> Strap does not tension</p>	<p>1. Tension force not adequate.</p> <p>2. Lubrication or contamination on wheels.</p> <p>3. Strap is jammed – strap guide cover loose.</p> <p>4. Primary tension pinch rollers are worn.</p>	<p>1. Adjust the tension force according to 4.14.</p> <p>2. Clean wheel surface.</p> <p>3. Fasten the strap cover plate.</p> <p>4. Change roller.</p>
<p> Strap is not being cut.</p>	<p>1. Dull or damaged strap cutter.</p> <p>2. Strap cut under tension.</p>	<p>1. Reverse or replace the strap cutter.</p> <p>2. Check adjustment of the home position (See section 4.2).</p>

7

Safety During Installation

7.1

Introduction


 The strapping machine has been designed to provide safe, efficient, and trouble-free service for many years. Component design and material selection have been carefully considered to ensure operator safety, ease of operation, and machine longevity. Our engineering and manufacturing procedures are designed to ensure consistent high quality.

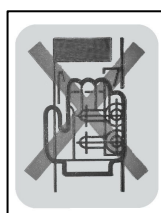
However, with any powered and/or automatic machine, there is a risk of damage or injury if appropriate precautions are not taken. Carefully read and understand Section 1, Safety PRECUTIONS, and related safety precautions in other sections of this manual before installing the strapping machine. The safety section details inherent risks and general safety considerations associated with the operation and maintenance of this machine.

Failure to follow the precautions could be result in equipment damage, personal injury, and/or loss of life. All installation personnel must be trained and qualified their particular job.

7.2

Safety Warnings

 Safety warning found in this manual and on the strapping machine indicate situation that require extra attention during installation of the machine. Observe the associated precautions carefully as they indicate potentially hazardous situations. The different warnings are

CAUTION**WARNING:****DANGER**

CAUTION: indicates a potentially hazardous situation which, if not avoided, may result in minor or moderate injury.

WANNING: indicates a potentially hazardous which, if not avoided, could result in death or serious injury.

DANGER: indicates an imminently hazardous situation, which if not avoid, will result in death or serious injury.

7.3

Personal Safety Provisions

The strapping machine is an automatic machine. Any inattention while close to the strapping machine could result in personal injury or equipment damage. Precautions must also be taken to avoid material being automatically conveyed to the strapping machine while it is not in service.

Shutting down the strapping does not necessary prevent other equipment in the line from operating. For all installation activities not requiring the strapping machine to be in operation, a lockout procedure applies. All personnel working on or around the strapping machine during installation must be qualified for their position.

7.4

Mechanical Safety

The following safety precautions must be observed when using or working the strapping machine:

- a. Never work on strapping machine when it is running.
- b. Never put any part of your body in the bundle opening when the strapping machine is in the automatic mode.
- c. Keep body and clothing clear of the conveyors (if so equipped), bundle stop (if so equipped), compactors (if so equipped) and strap coils when the strapping machine is running.
- d. Never circumvent safety switches or operate the strapping machine with the safety guarding removed or any doors opened or removed.
- e. Do not stand, sit, or lie on the strapping machine.
- f. The use of suitable eye and ear protection is required when operating the strapping machine or performing certain maintenance functions.
- g. Appropriate footwear is required when moving the strapping machine.


7.5

Electrical Safety

The following safety precautions must be observed when installing or working on the strapping machine:

- a. Ensure the power source for the strapping machine is the correct voltage and current rating.
- b. Verify the strapping machine is properly grounded to the facility ground.
- c. Do not use the strapping machine is a wash down application.
- d. Do not remove plug-in cables with the power supply under load.


7.6 Pneumatic Safety (If So Equipped)

 The following safety precautions must be observed when using or working on the strapping machine:

1. Do not exceed the maximum operation pressure of the strapping machine.
2. Inspect all connections, hoses, and fittings on a regular basis.
3. Periodically check strapping machine pneumatic component operation.
4. Ensure that all components are correctly assembled before applying air pressure.

Carefully read and under the safety sections of the manual before installing the strapping machine. The safety sections of this manual identify general safety issue and inherent risks associated with the strapping machine. Failure to follow this precaution may result in personal injury and or equipment damage.

7.7 General Product Information

 The strapping machine is to be manually rolled into place or lifted with a forklift suitable for the weight of this equipment. Do not lift the strapping by the arch.

Approximate Weight:

Strapping Machine: 440 lbs / 200 kg.
Coil: 26lbs / 12 kg

7.8 Installing The Strapping Machine


 The following procedure must be followed for the proper installation of the strapping machine.

1. Turn the ON/OFF switch to the “OFF” position.
2. Plug machine into a properly sized and ground power source.
3. Connect to compressed air supply.
4. Lock caster to prevent unintentional rolling.
5. Refer to “Starting the Strapping Machine” and “Loading the Strap”.


8

Safety During De-Installation


8.1 Introduction

 Read this section of the manual carefully before you start de-installation of the strapping machine, as it deals with potential risks occurring during de- installation. Failure to follow mentioned precautions and safety warnings could result in personal injury. Before starting electrical de-installation activities on the strapping machine, ensure that all electrical sources are disconnected.


8.2 General product information

 The strapping machine is to be manually rolled into place or lifted with a forklift suitable for the weight of this equipment only. DO NOT lift the strapping machine by the arch.

8.3 Clearing the strapping machine

 Remove the strap from the strapping machine as described “Unloading the strap”.

8.4 Electrical shutdown of the strapping machine

 Prior to unplugging the strapping machine, verify that ON/OFF switch is in the “OFF” position. All the local codes pertaining to electrical activities must be followed.

WARNING: The shut down procedure must be followed for all work performed on the strapping machine electrical circuit. High voltage represents a life threatening danger.

SV-5000C

**PARTS LIST
FOR
AUTOMATIC STRAPPING MACHINE**

POLYCHEM Corporation

6277 Heisley Road, Mentor OH 44060.
TEL : 440-358-7060 FAX : 440-358-7061

Control Unit

9.1

Cam unit

Fig-1A

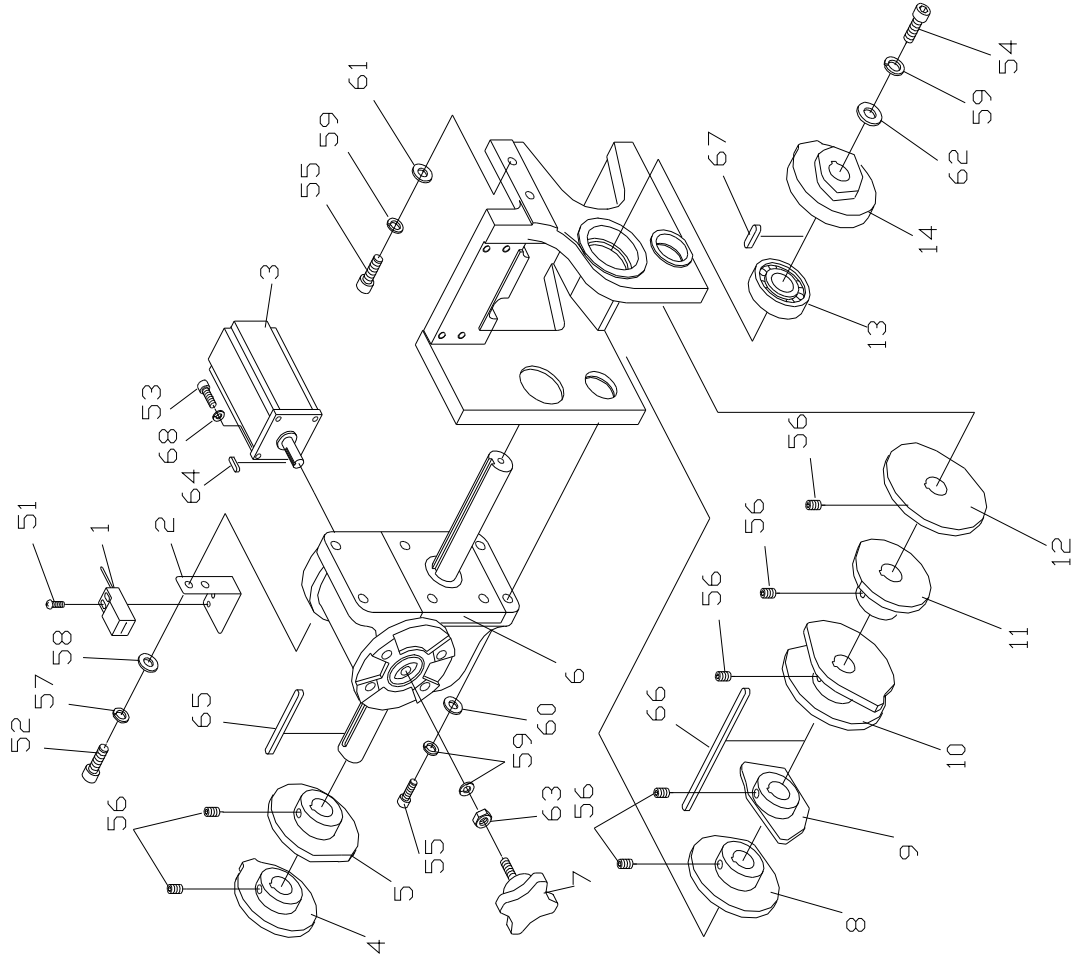


Fig-1A **Cam unit**

No.	Part no.	Part name	Part Name	Quantity
1	A68-1A0101	Proximity switch		1
2	A68-1A0102	Bracket for proximity switch		1
3	A68-1A0103-1	Servo motor (see Appendix A)	Yaskawa (old), until August 31th, 2010	1
	A68-1A0103-2	Servo motor (see Appendix A)	Yaskawa (new), September, 2010 - present	1
4	A68-1A0104	Cam for home position.		1
5	A68-1A0105	Cam for arch opening		1
6	A68-1A0106	Gear Reducer		1
7	A68-1A0107	Plastic turning knob		1
8	A68-1A0108	Cam - slide table		1
9	A68-1A0109	Cam - left gripper		1
10	A68-1A0110	Cam – Press bar with cutter		1
11	A68-1A0111	Cam – front gripper		1
12	A68-1A0112	Cam - heater		1
13	A68-1A0113	Bearing.		1
14	A68-1A0114	Cam – tension		1
51	A68-1A0151	TMS 3x25		2
52	A68-1A0152	HBS 4x8		2
53	A68-1A0153	HBS 5x15		4
54	A68-1A0154	HBS 6x15		1
55	A68-1A0155	HBS 6x25		6
56	A68-1A0156	HSS 6x10		7
57	A68-1A0157	SW 4mm		2

2012.02

Fig-1A Cam unit

No.	Part No.	Part Name	Part Name	Quantity
58	A68-1A0158	PW 4mm		2
59	A68-1A0159	SW 6mm		7
60	A68-1A0160	PW 6mm		4
61	A68-1A0161	PW 6mm (19)		2
62	A68-1A0162	PW 6mm (25)		1
63	A68-1A0163	HN 6mm		1
64	A68-1A0164	KYA		1
65	A68-1A0165	KYA		1
66	A68-1A0166	KYA		1
67	A68-1A0167	KYA		1
68	A68-1A0168	SW 5mm		4

Control Unit

9.1

Fig-1B-AB

Slide Table Unit

Fig-1B SLIDE TABLE UNIT

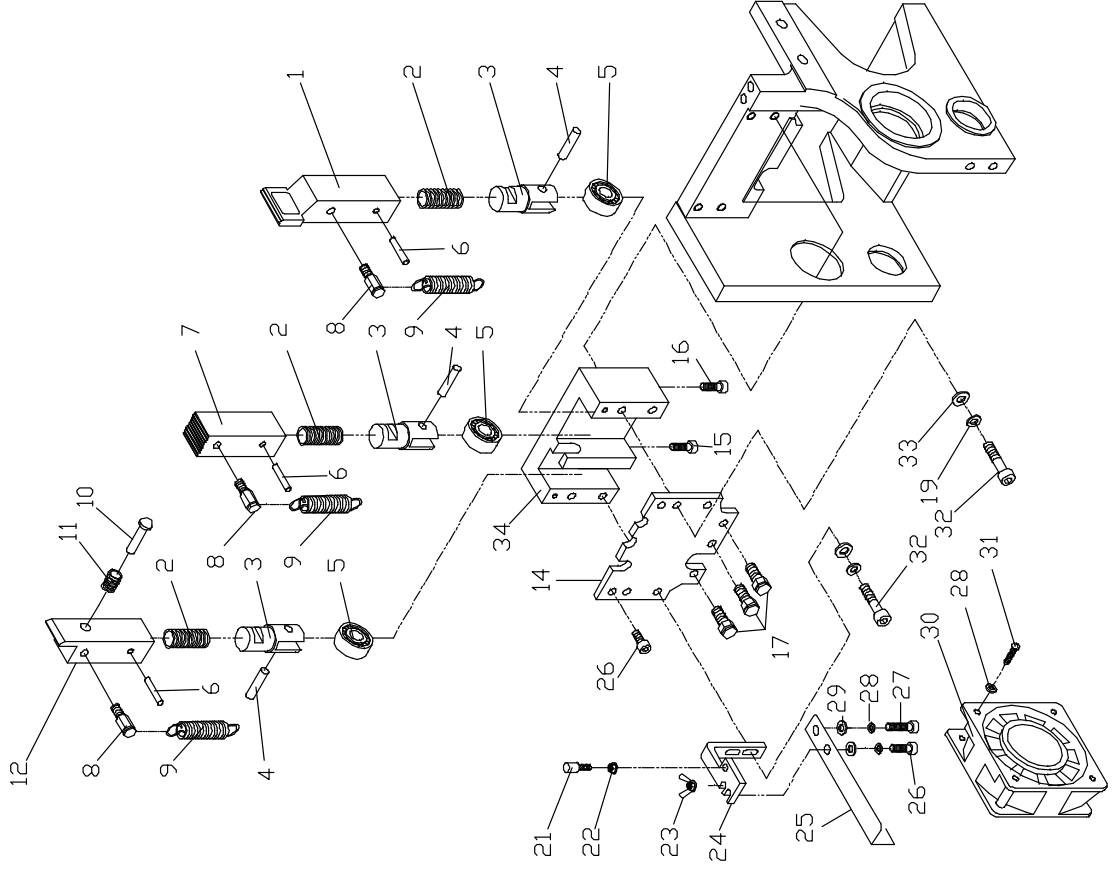


Fig-1B-AB Slide Table Unit

No.	Part No.	Part Name	Part Name	Quantity
1	A68-1B0221	Front Gripper		1
2	A68-1B0220	Compression Spring		3
3	A68-1B0219	Shaft of cutter		3
4	A68-1B0288	SP 5 mm		3
5	A68-1B0218	Bearing		3
6	A68-1B0287	SP 3 mm		3
7	A68-1B0222	Press bar		1
8	A68-1B0226	Hexagon screw		3
9	A68-1B0227	Spring		3
10	A68-1B0225	Plastic		1
11	A68-1B0224	Spring		1
12	A68-1B0223	Rear gripper		1
14	A68-1B0229	Cover of gripper bracket		1
15	A68-1B0292	HBS 4x25		1
16	A68-1B0268	HBS 5x15		1
17	A68-1B0230	Hexagon screw		3
21	A68-1B0232	Plastic pad		1
22	A68-1B0286	FLG 6mm		1
23	A68-1B02103	HN 4 mm		1
24	A68-1B0233	L type bracket		1
25	A68-1B0236	Fan bracket		3
26	A68-1B0262	HBS 4x8		1
27	A68-1B02104	HBS 4x12		4
28	A68-1B0277	SW 4mm		2

2012.02

Fig-1B-AB

Slide Table Unit

No.	Part No.	Part Name	Part Name	Quantity
29	A68-1B0278	PW 4mm		1
30	A68-1B0237	Fan		2
31	A68-1B0265	PMS 4x30		4
32	A68-1B0274	HBS 6x55		3
33	A68-1B0283	PW 6mm		4
34	A68-1B0228	Gripper bracket		1

Control Unit

9.2

Fig-2B-AB

Slide Table Unit

Fig-2B SLIDE TABLE UNIT

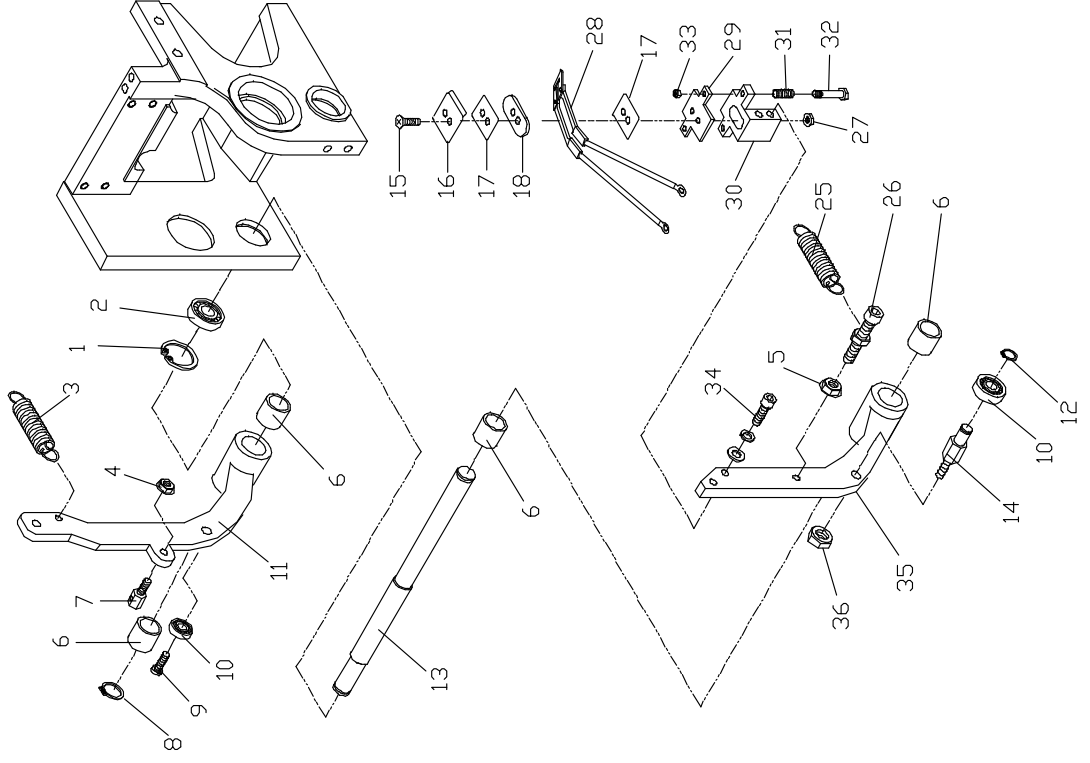


Fig-2B-AB Slide Table Unit

No.	Part No.	Part Name	Part Name	Quantity
1	A68-2B0290	RR		2
2	A68-2B0241	Bearing		2
3	A68-2B0238	Spring		1
4	A68-2B02105	FLG 8mm		1
5	A68-2B0286	FLG 6mm		1
6	A68-2B0208	Self lubricating bearing		4
7	A68-2B0239	Hexagon screw		1
8	A68-2B0289	SR		1
9	A68-2B0212	Hexagon screw		1
10	A68-2B0211	Bearing 628		2
11	A68-2B0240	Swing leveler of arch		1
12	A68-2B0291	SR		1
13	A68-2B0248	Shaft		1
14	A68-2B0250	Hexagon shaft		1
15	A68-2B0264	FMS 4x12		2
16	A68-2B0243	Stainless plate		1
17	A68-2B0244	Heat insulation plate		2
18	A68-2B0245	Bakelite		1
25	A68-2B0251	Spring		1
26	A68-2B0273	HBS 6x45		1
27	A68-2B02106	FLG 4mm		2
28	A68-2B02109	Heater		1
29	A68-2B02110	Heater Bracket		1

Fig-2B-AB Slide Table Unit

No.	Part No.	Part Name	Part Name	Quantity
30	A68-AB02111	Bracket		1
31	A68-AB02112	Spring		2
32	A68-2B02113	Heater Screw		2
33	A68-2B02114	Locking nut		2
34	A68-2B 0268	HBS 5x15		2
35	A68-2B 02115	Heater arm		1
36	A68-2B02116	HN 8mm		1

Control Unit

9.1

Slide Table Unit

Fig-3B

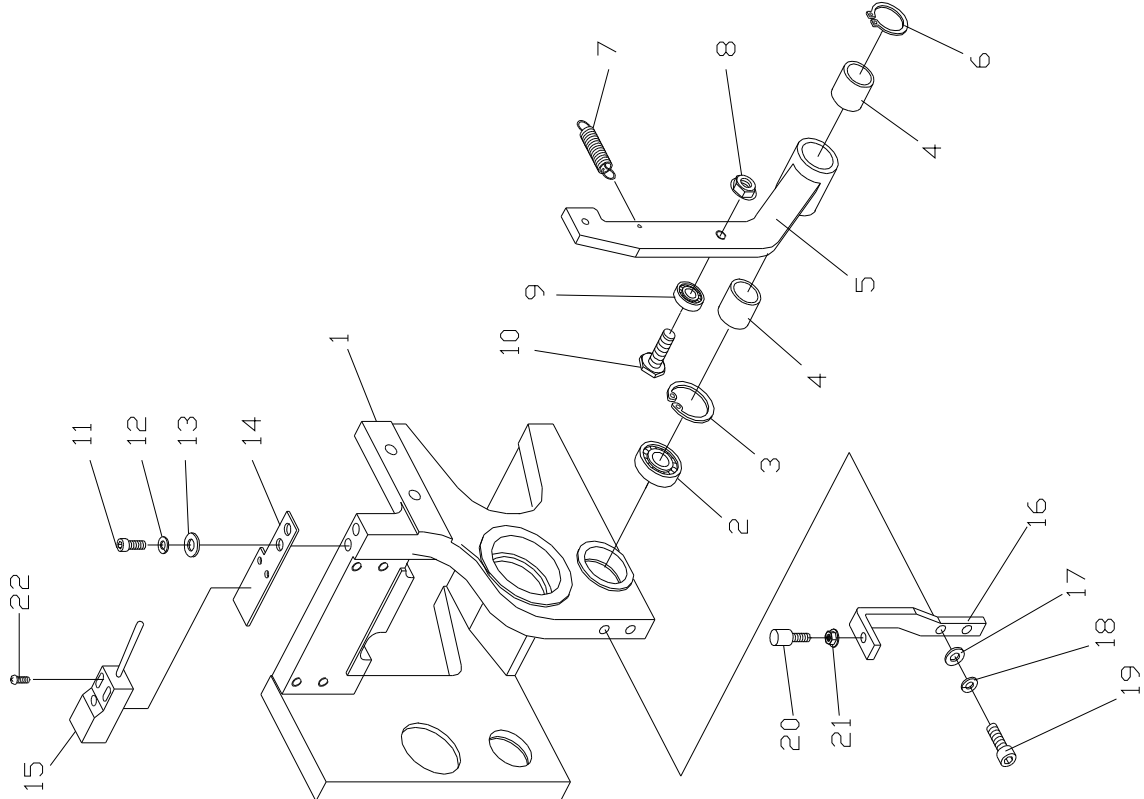


Fig-3B Slide Table Unit

No.	Part No.	Part Name	Part Name	Quantity
1	A68-3B0201	Sealing head Housing		1
2	A68-3B0241	Bearing		1
3	A68-3B0290	RR		1
4	A68-3B0208	Self lubricating bearing		2
5	A68-3B0252	Track swing pole		1
6	A68-3B0289	SR		1
7	A68-3B0253	Spring		1
8	A68-3B0285	FLG 5mm		1
9	A68-3B0254	Bearing 635		1
10	A68-3B02108	FMS 5x16		1
11	A68-3B0262	HBS 4x8		2
12	A68-3B0277	SW 4mm		2
13	A68-3B0278	PW 4mm		2
14	A68-3B0202	Bracket for proximity switch		1
15	A68-3B0203	Proximity switch		1
16	A68-3B0299	Bracket		1
17	A68-3B0280	PW 5mm		2
18	A68-3B0279	SW 5mm		2
19	A68-3B0268	HBS 5x15		1
20	A68-3B0232	Plastic pad		1
21	A68-3B0286	FLG 6mm		1
22	A68-3B02107	TMS 3x16		2

Control Unit

9.1

Fig-4B

Slide Table Unit

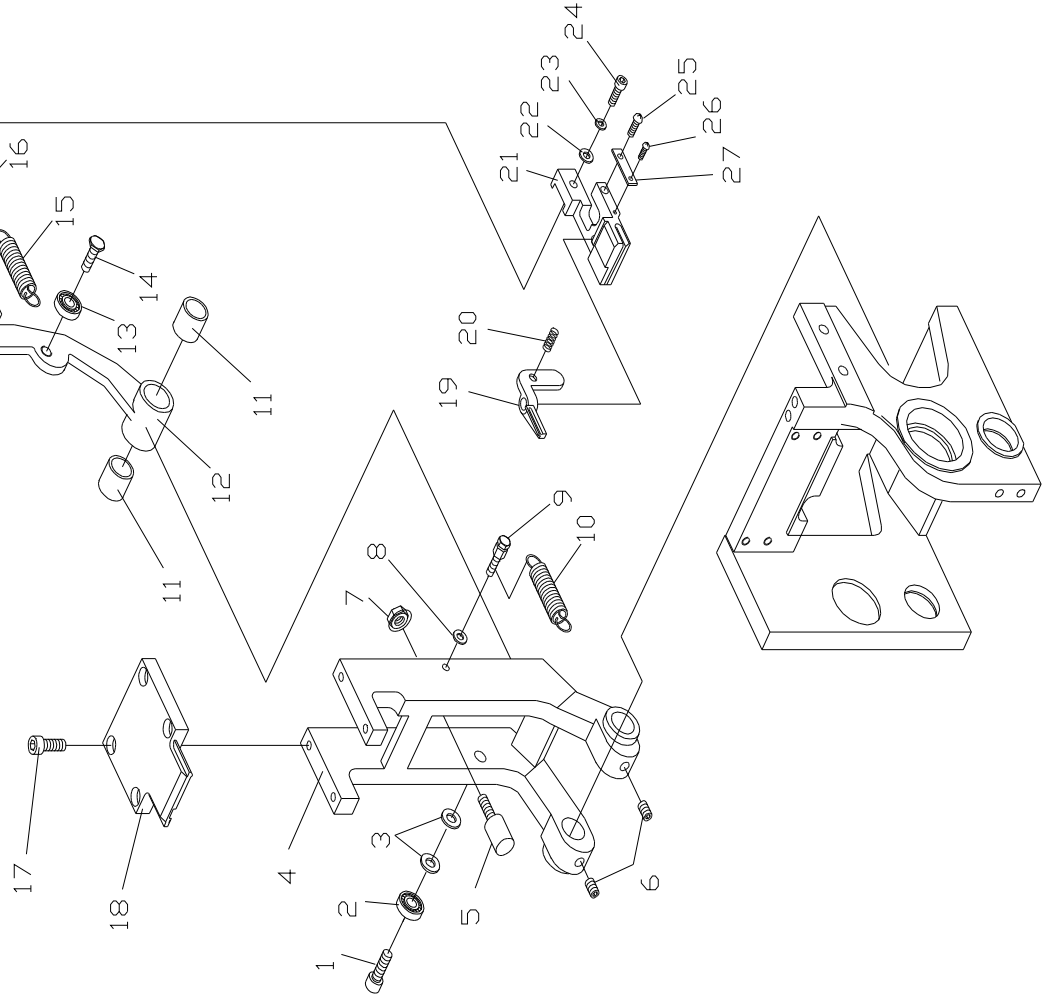


Fig-4B Slide Table Unit

No.	Part No.	Part Name	Part Name	Quantity
1	A68-4B0276	HBS 8x15		1
2	A68-4B0204	Bearing		1
3	A68-4B0284	SW 8mm		2
4	A68-4B0206	Slide table arm		1
5	A68-4B0205	Rubber pad (with screw)		1
6	A68-4B0275	HSS 6x10		2
7	A68-4B0286	FLG 6mm		1
8	A68-4B0282	SW 6mm		1
9	A68-4B0210	HEX Screw		1
10	A68-4B02100	Spring		1
11	A68-4B0208	Self lubricating bearing		2
12	A68-4B0209	Inner slide table arm		1
13	A68-4B0211	Bearing		1
14	A68-4B0212	Hexagon screw		1
15	A68-4B02101	Spring		1
16	A68-4B0213	Hexagon		1
17	A68-4B0271	HBS 6x15		4
18	A68-4B0207	Slide table		1
19	A68-4B0217	Striker		1
20	A68-4B0216	Spring		1
21	A68-4B0215	Inner slide table		1
22	A68-4B0280	PW 5mm		1
23	A68-4B0279	SW 5mm		1
24	A68-4B0268	HBS 5x15		1

2012.02

Fig-4B Slide Table Unit

No.	Part No.	Part Name	Part Name	Quantity
25	A68-4B0266	THS 5x10		1
26	A68-4B0263	THS 4x6		1
27	A68-4B0214	Washer		1

Cam Unit

9.2

Roller Block Unit

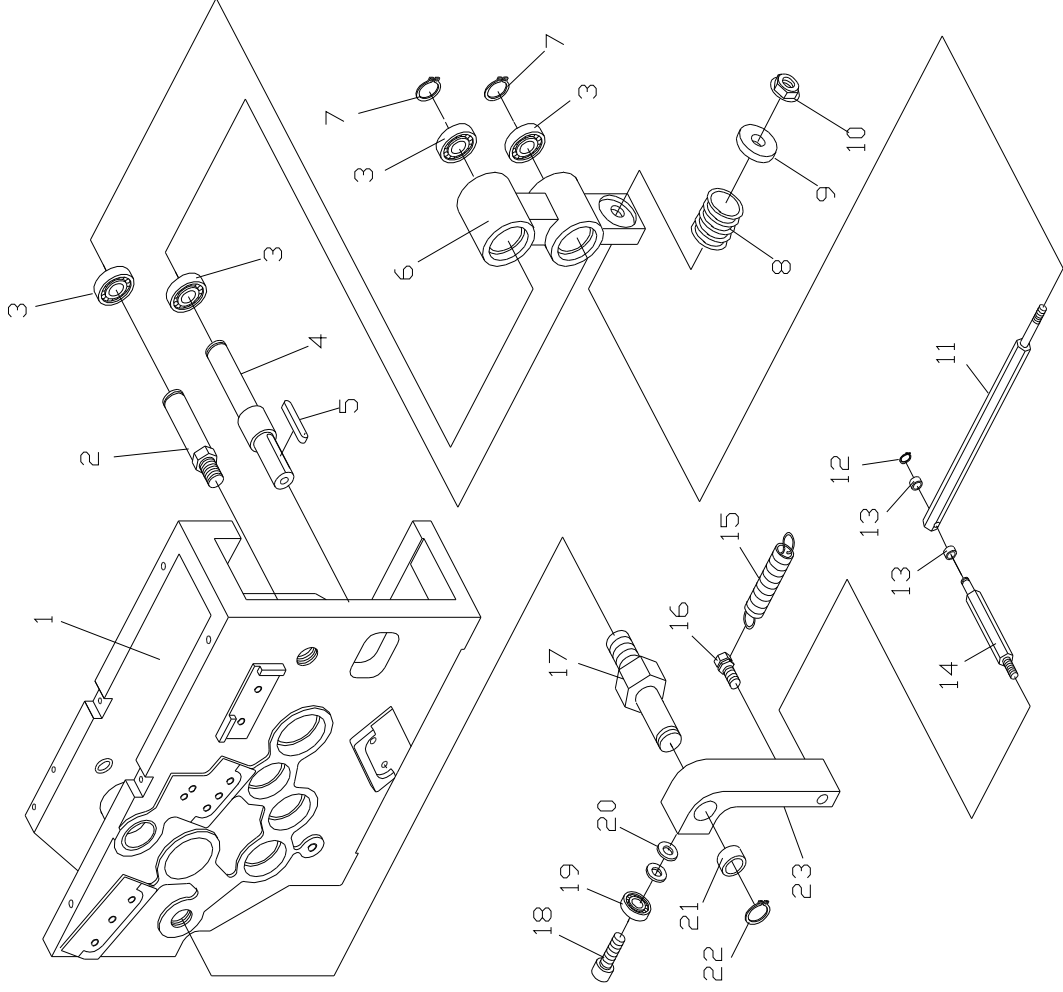


Fig-1C

Fig-1C Roller Block Unit

No.	Part No.	Part Name	Part Name	Quantity
1	A68-1C0301	Feeding, re-tracking housing		1
2	A68-1C0305	Tension Roller shaft		1
3	A68-1C0306	Bearing 6002		4
4	A68-1C0304	Shaft		1
5	A68-1C0374	KYA		1
6	A68-1C0307	Shaft housing		1
7	A68-1C0375	SR		2
8	A68-1C0303	Compression spring		1
9	A68-1C0302	Round head screw		1
10	A68-1C0373	FLG 8mm		1
11	A68-1C0312	Hexagon shaft		1
12	A68-1C0376	SR		1
13	A68-1C0313	Self-lubricated bearing		2
14	A68-1C0314	Hexagon shaft		1
15	A68-1C0322	Spring		1
16	A68-1C0321	Hex screw		1
17	A68-1C0318	Hexagon shaft		1
18	A68-1C0361	HBS 8x15		1
19	A68-1C0319	Bearing		1
20	A68-1C0369	SW 8mm		2
21	A68-1C0382	Self-lubricated bearing		1
22	A68-1C0379	SR		1
23	A68-1C0320	Cam for tensioning		1

9.2

Cam Unit

Fig.-3C-AB

Roller Block Unit

Fig- 3C ROLLER BLOCK UNIT

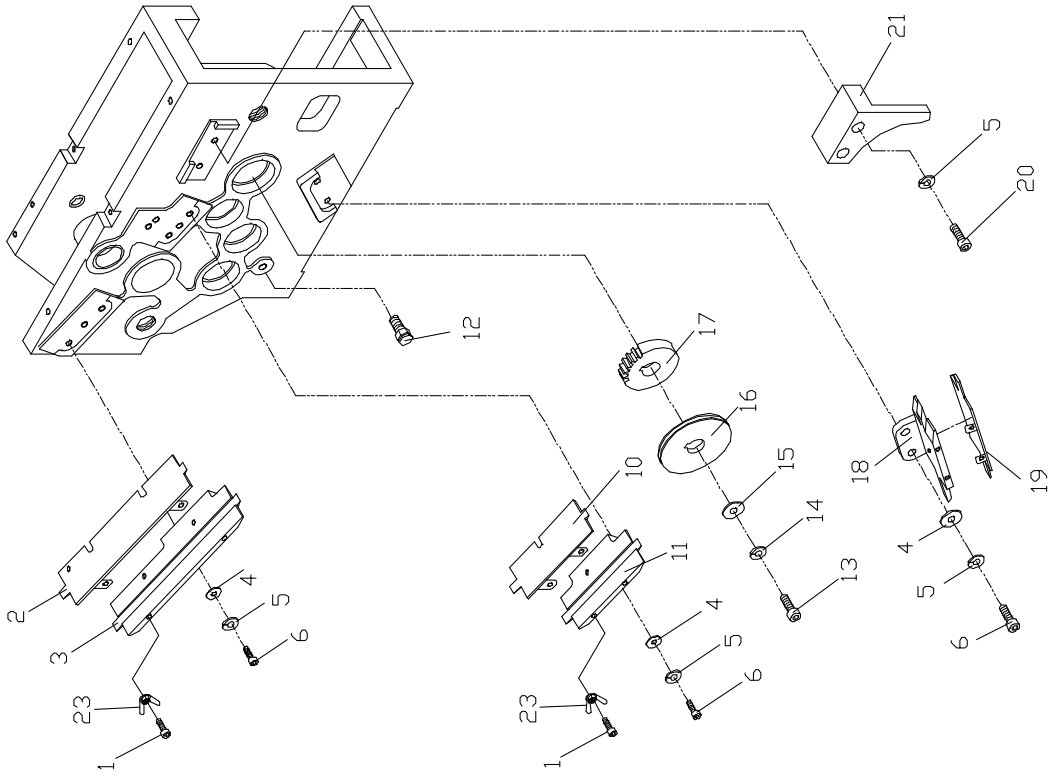


Fig.-3C-AB

Roller Block Unit

No.	Part No.	Part Name	Part Name	Quantity
1	A68-3C0384	HBS 4x12		6
2	A68-3C0325-1	Strap guide plate	(5-6mm)	1
	A68-3C0325-2	Strap guide plate	(9mm)	1
3	A68-3C0326-1	Strap chute	(5-6mm)	1
	A68-3C0326-2	Strap chute	(9mm)	1
4	A68-3C0365	PW 5mm		3
5	A68-3C0364	SW 5mm		3
6	A68-3C0356	HBS 5x20		3
10	A68-3C0327	Strap guide plate		1
11	A68-3C0328-1	Strap guide	(5-6mm)	1
	A68-3C0328-2	Strap guide	(9mm)	1
12	A68-3C0321	Hex screw		1
13	A68-3C0359	HBS 6x15		1
14	A68-3C0367	SW 6mm		1
15	A68-3C0368	PW 6mm (25)		1
16	A68-3C0330-1	Tension roller - lower	(5-6mm)	1
	A68-3C0330-2	Tension roller – lower	(9mm)	1
17	A68-3C0331	Gear		1
18	A68-3C0333-1	Strap guide	(5-6mm)	1
	A68-3C0333-2	Strap guide	(9mm)	1
19	A68-3C0334	Strap guide plate		1
20	A68-3C0357	HBS 5x25		2

Fig.-3C-AB Roller Block Unit

No.	Part No.	Part Name	Part Name	Quantity
21	A68-3C0332-1	Guide plate	(5-6mm)	1
	A68-3C0332-2	Guide plate	(9mm)	1
23	A68-3C0386	Nut 4mm		6

Cam Unit

9.2

Fig.-4C-AB

Roller Block Unit

Fig-4C ROLLER BLOCK UNIT

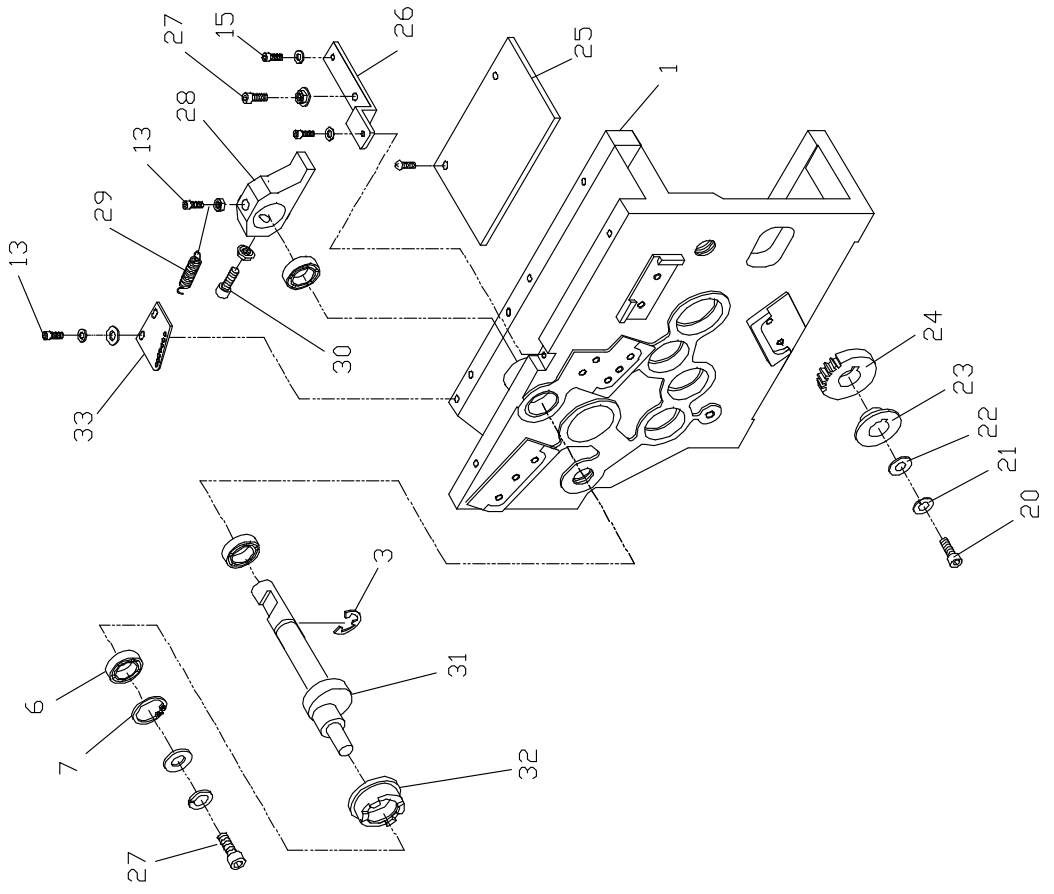


Fig.-4C-AB

Roller Block Unit

No.	Part No.	Part Name	Part Name	Quantity
1	A68AB-4C0386	Feeding, re-tracking housing		1
3	A68AB-4C0378	ER		1
6	A68AB-4C0317	Bearing 628		1
7	A68AB-4C0377	RR		1
13	A68AB-4C0353	HBS 4x8		2
15	A68AB-4C0384	HBS 4x12		1
20	A68AB-4C0359	HBS 6x15		1
21	A68AB-4C0367	SW 6mm		1
22	A68AB-4C0368	PW 6mm (25)		1
23	A68AB-4C0335-1	Tension roller - upper	(5-6mm)	1
	A68AB-4C0335-2	Tension roller - upper	(9mm)	1
24	A68AB-4C0331	Gear		1
25	A68AB-4C0396	Roller Block Cover		1
26	A68AB-4C0397	Sleeve for fixing shaft		1
27	A68AB-4C0398	HBS 5x15		2
29	A68AB-4C03100	Spring		1
30	A68AB-4C03101	HBS 5x12		1
31	A68AB-4C03102	Feed, re-tracking roller shaft		1
32	A68AB-4C0316	Upper Re-tracking roller		1
33	A68AB-4C0403	Spring holder plate		1

9.2

Fig.-1D-AB

Roller Block Unit

Fig-1D ROLLER BLOCK UNIT

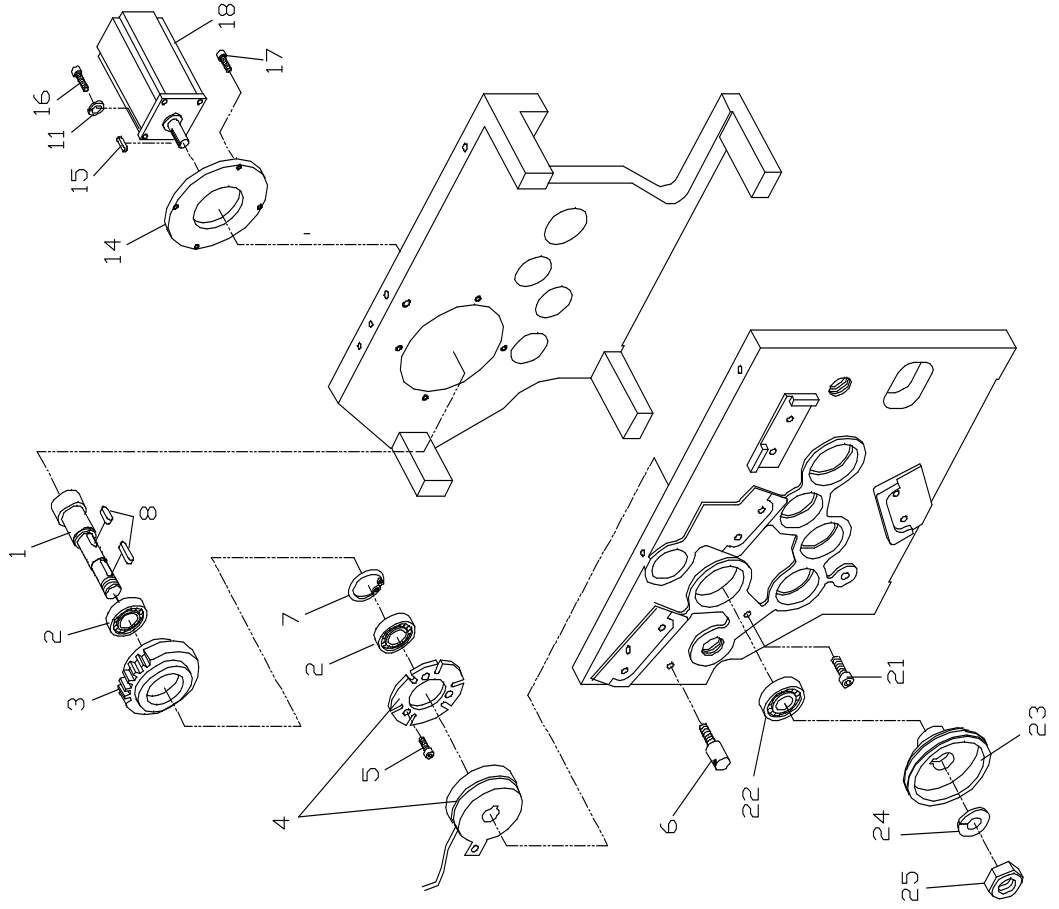


Fig.-1D-AB Roller Block Unit

No.	Part No.	Part Name	Part Name	Quantity
1	A68-1D0405	Feeding, re-tracking shaft		1
2	A68-1D0406	Bearing		2
3	A68-1D0407	Gear		1
4	A68-1D0408	Clutch		1
5	A68-1D0451	HBS 3x6		3
6	A68-1D0416	Round Head screw		1
7	A68-1D0466	RR		1
8	A68-1D0460	KYA		2
9	A68-1D0404-1	Spring	(5-6mm)	1
	A68-1D0404-2	Spring	(9mm)	1
10	A68-1D0452	HBS 4x8		2
11	A68-1D0456	SW 4mm		9
12	A68-1D0403	Spring holder plate		1
13	A68-1D0471	PW 4mm		2
14	A68-1D0402	Motor fixing bracket		1
15	A68-1D0459	KYA		1
16	A68-1D0454	HBS 4x16		4
17	A68-1D0453	HBS 4x12		4
18	A68-1D0401-1	Servo motor (see Appendix A)	Yaskawa (old) until August 30th, 2010	1
	A68-1D0401-2	Servo motor (see Appendix A)	Yaskawa (new) September, 2010 - present	1
19	A68-1D0470	TMS 4x6		2
20	A68-1D0469	Roller Block Cover		1

Fig.-1D-AB Roller Block Unit

No.	Part No.	Part Name	Part Name	Quantity
21	A68-1D0468	HBS 4x12		1
22	A68-1D0417	Bearing		1
23	A68-1D0419-1	Feed/Re-tracking roller	(5-6mm)	1
	A68-1D0419-2	Feed/Re-tracking roller	(9mm)	1
24	A68-1D0472	SW 14mm		1
25	A68-1D0473	HN 14mm		1

Cam Unit

9.2

Fig.-2D

Roller Block Unit

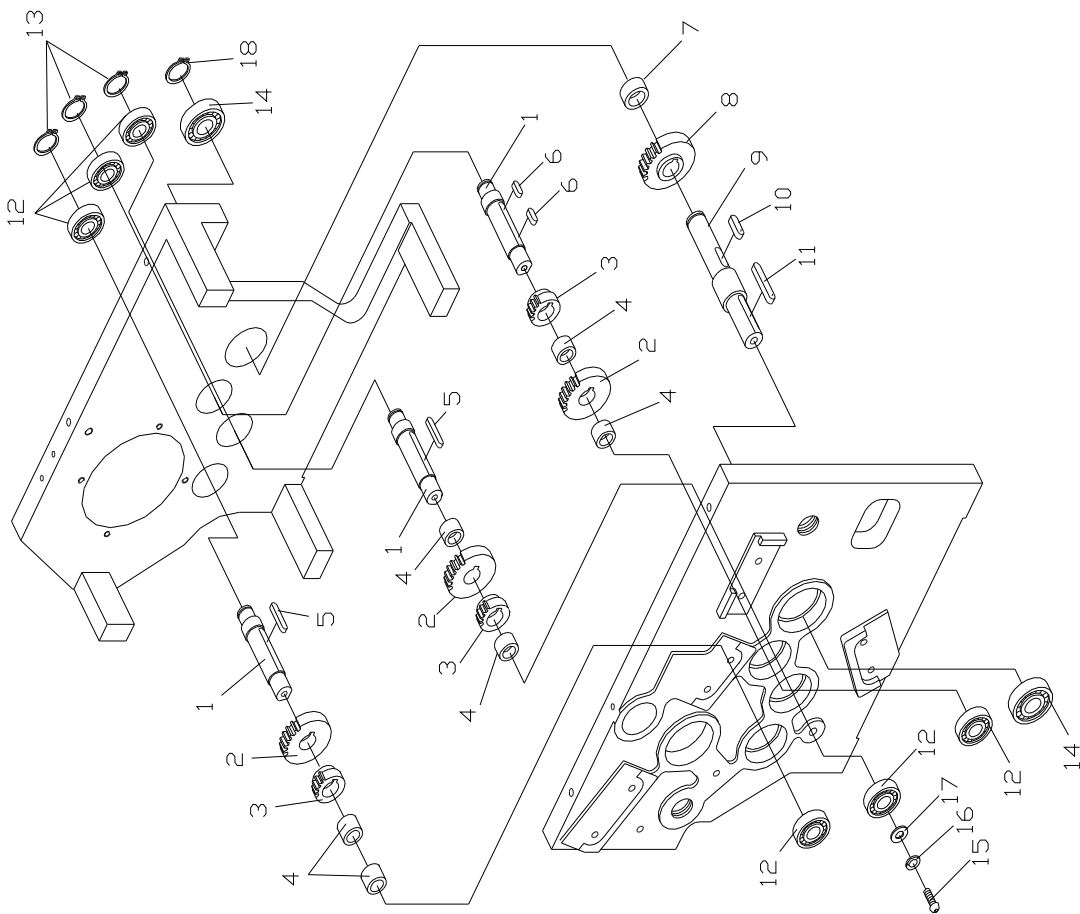


Fig.-2D Roller Block Unit

No.	Part No.	Part Name	Part Name	Quantity
1	A68-2D0412	Gear Shaft		3
2	A68-2D0411	Gear		3
3	A68-2D0410	Gear		3
4	A68-2D0409	Shim		6
5	A68-2D0461	KYA 4x24		2
6	A68-2D0462	KYA 4x12		2
7	A68-2D0413	Shim		1
8	A68-2D0414	Gear		1
9	A68-2D0415	Gear Shaft		1
10	A68-2D0463	KYA		1
11	A68-2D0464	KYA		1
12	A68-2D0418	Bearing 6001		6
13	A68-2D0465	SR		3
14	A68-2D0417	Bearing		2
15	A68-2D0455	THS 5x10		3
16	A68-2D0457	SW 5mm		3
17	A68-2D0458	PW 5mm (16)		3
18	A68-2D0467	ER		1

Accumulator Unit

9.3

Fig.-2E

Accumulator Box

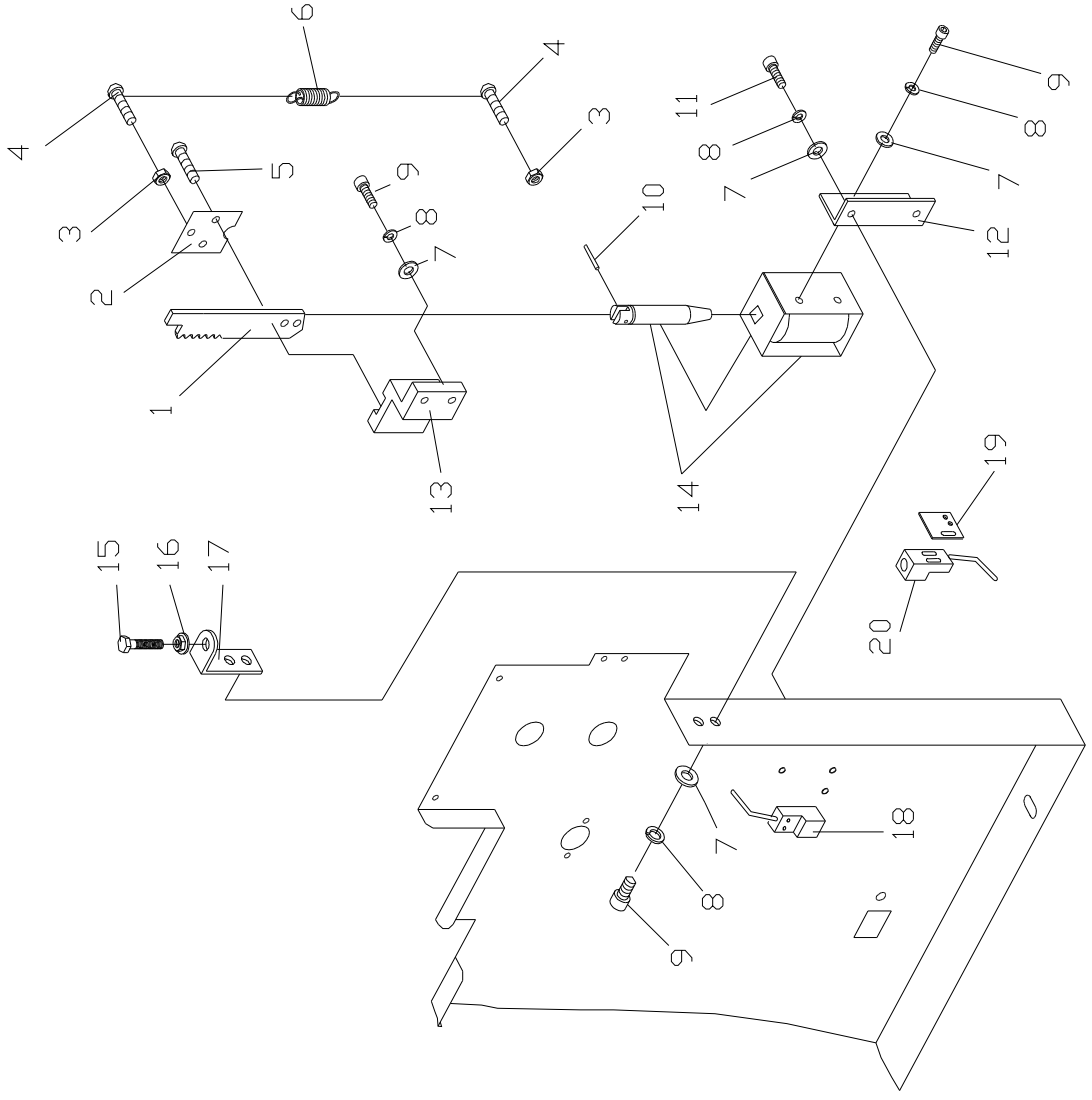


Fig.-2E Accumulator Box

No.	Part No.	Part Name	Part Name	Quantity
1	A68-2E0535	Gear rack		1
2	A68-2E0536	Gear rack cover		1
3	A68-2E0569	HN 4mm		2
4	A68-2E0554	PMS 4x8		2
5	A68-2E0551	TMS 4x6		2
6	A68-2E0537	Spring		1
7	A68-2E0565	PW 4mm		8
8	A68-2E0564	SW 4mm		10
9	A68-2E0555	HBS 4x8		6
10	A68-2E0572	SP 3mm		1
11	A68-2E0553	HBS 4x6		2
12	A68-2E0532	Fixing bracket of solenoid		1
13	A68-2E0534	Gear rack bracket		1
14	A68-2E0533	Solenoid		1
15	A68-2E0582	Hexagon screw		1
16	A68-2E0570	FLG 5mm		1
17	A68-2E0583	L type bracket		1
18	A68-2E0519	Proximity switch		1
19	A68-2E0527	Bracket for proximity switch		1
20	A68-2E0525	Proximity switch		1

9.3

Accumulator Unit

Fig.-3E

Accumulator Box

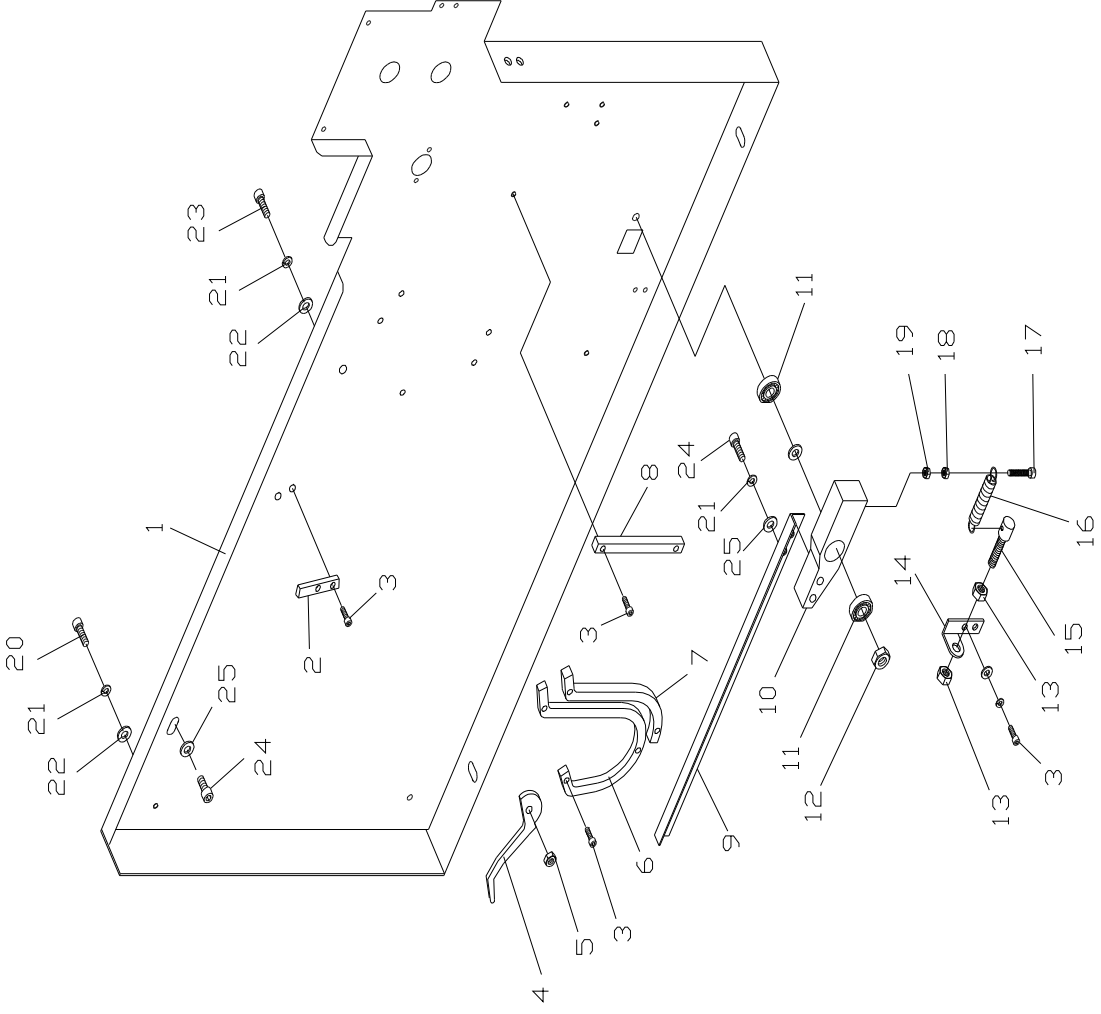


Fig.-3E Accumulator Box

No.	Part No.	Part Name	Part Name	Quantity
1	A68-3E0508	Accumulator		1
2	A68-3E0585	Guide plate		1
3	A68-3E0555	HBS 4x8		11
4	A68-3E0510-1	Strap guide	(5~6mm)	1
	A68-3E0510-2	Strap guide	(9mm)	1
5	A68-3E0584	FLG 6mm		1
6	A68-3E0509-1	Strap Guide	(5~6mm)	1
	A68-3E0509-2	Strap Guide	(9mm)	1
7	A68-3E0509-1	Strap Guide	(5~6mm)	1
	A68-3E0509-2	Strap Guide	(9mm)	1
8	A68-3E0513	Guide plate		1
9	A68-3E0518	Balance Bar		1
10	A68-3E0517	Balance bar fixing bracket		1
11	A68-3E0516	Bearing 605		2
12	A68-3E0570	FLG 5mm		1
13	A68-3E0584	FLG 6mm		2
14	A68-3E0514	Pinch tension holding plate		1
15	A68-3E0512	Adjust Bolt M6x40		1
16	A68-3E0515	Spring		1
17	A68-3E0586	PMS 4x30		1
18	A68-3E0569	HN 4mm		1
19	A68-3E0568	FLG 4mm		1
20	A68-3E0587	HBS 5x30		4
21	A68-3E0566	SW 5mm		9

Fig.-3E **Accumulator Box**

No.	Part No.	Part Name	Part Name	Quantity
22	A68-3E0567	PW 5mm (14)		9
23	A68-3E0574	HBS 5x25		5
24	A68-3E0559	HBS 5x10		5
25	A68-3E0588	PW 5mm (12)		4

Accumulator Unit

9.3

Accumulator Box

Fig.-4E

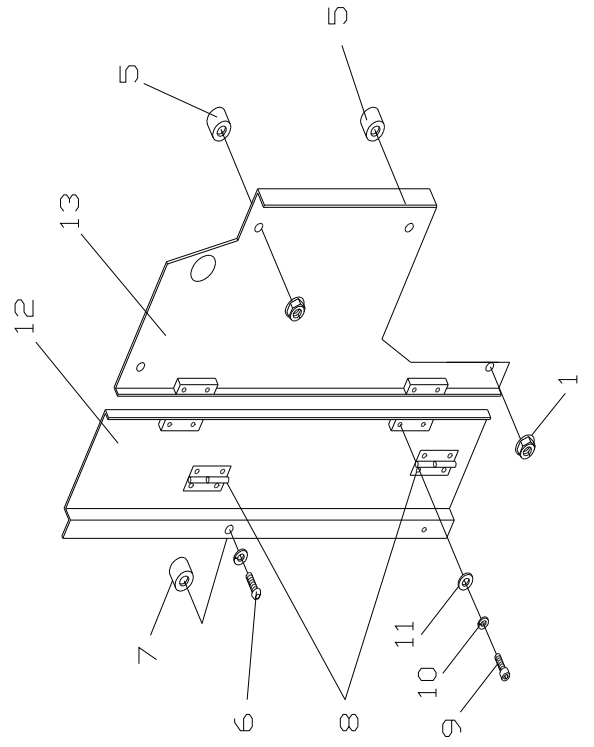
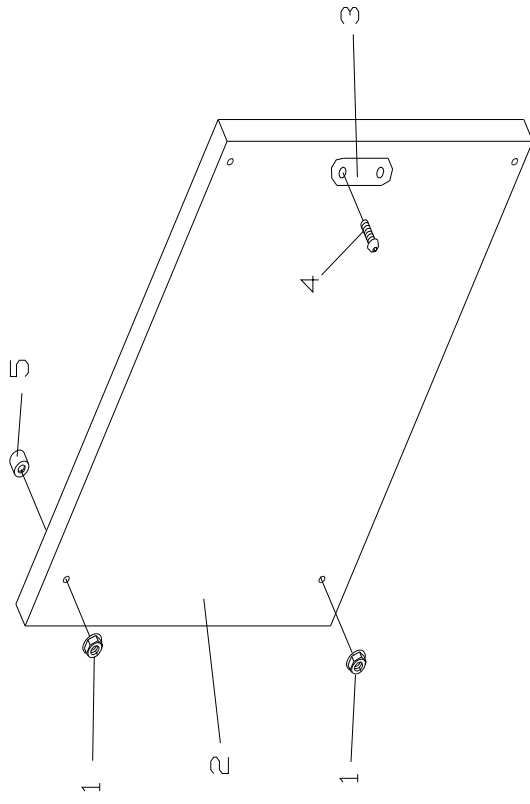


Fig.-4E Accumulator Box

No.	Part No.	Part Name	Part Name	Quantity
1	A68-4E0570	FLG 5mm		8
2	A68-4E0543	Accumulator cover – left		1
3	A68-4E0576	Accumulator cover		1
4	A68-4E0552	THS 4x6		2
5	A68-4E0538	Hex screw		8
6	A68-4E0581	THS 5x10		1
7	A68-4E0541	Solenoid		1
8	A68-4E0542	Door latch		2
9	A68-4E0579	HBS 4x10		8
10	A68-4E0564	SW 4mm		8
11	A68-4E0565	PW 4mm		8
12	A68-4E0540	Accumulator cover – center		1
13	A68-4E0539	Accumulator cover – right		1

Accumulator Unit

9.3

Fig.-5E-AB
Accumulator Box

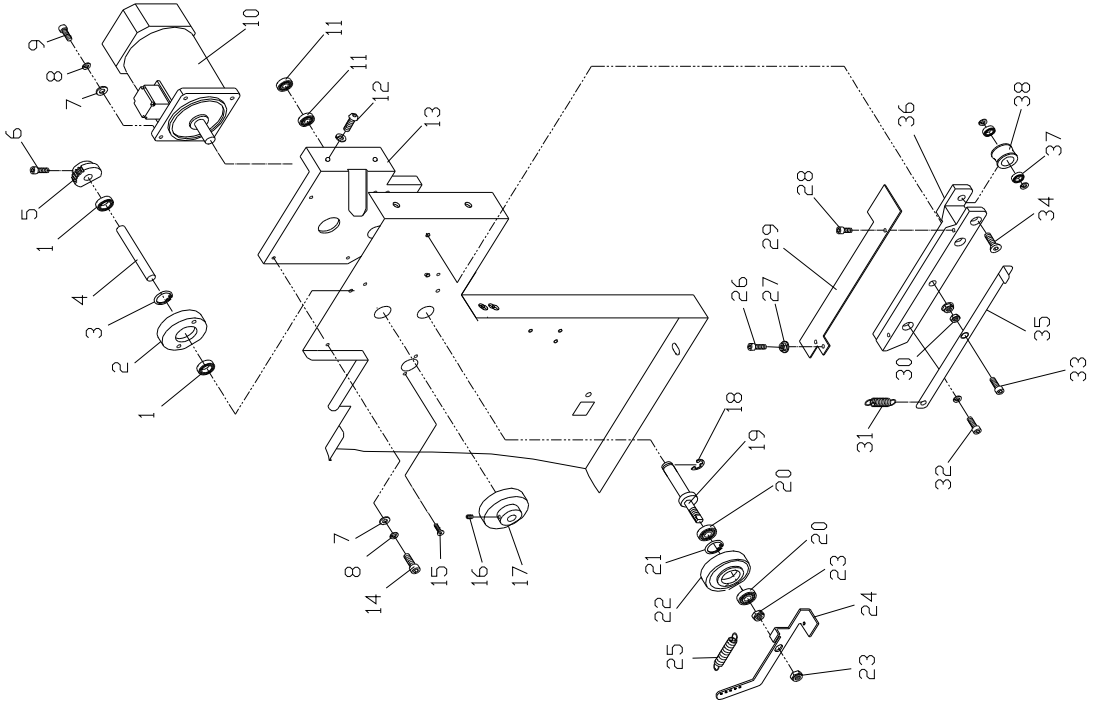


Fig.-5E-AB Accumulator Box

No.	Part No.	Part Name	Part Name	Quantity
1	A68AB-5E0505	Bearing 626		2
2	A68AB-5E0507	Bearing fixing bracket		1
3	A68AB-5E0577	RR-19		1
4	A68AB-5E0506	Rod		1
5	A68AB-5E0504	Gear		1
6	A68AB-5E0555	HBS 4x8		1
7	A68AB-5E0567	PW 5mm		7
8	A68AB-5E0566	SW 5mm		4
9	A68AB-5E0560	HBS 5x18		4
10	A68AB-5E0501	Motor		1
11	A68AB-5E0502	Bearing 6800		2
12	A68AB-5E0581	THS 5x10		2
13	A68AB-5E0503	Motor fixing bracket		1
14	A68AB-5E0559	HBS 5x10		3
15	A68AB-5E0556	FMS 4x10		2
16	A68AB-5E0563	HSS 6X10		1
17	A68AB-5E0511	Idle roller		1
18	A68AB-5E0573	ER - 8		1
19	A68AB-5E0520	Shaft		1
20	A68AB-5E0522	Bearing 628		2
21	A68AB-5E0578	RR-24		1
22	A68AB-5E0521	Upper feeding roller		1
23	A68AB-5E0571	FLG 8mm		2
24	A68AB-5E0523	Bracket		1

Fig.-5E-AB Accumulator Box

No.	Part No.	Part Name	Part Name	Quantity
25	A68AB-5E0524	Spring		1
26	A68AB-5E0579	HBS 4x10		1
27	A68AB-5E0568	FLG 4mm		1
28	A68AB-5E0553	HBS 4x6		1
29	A68AB-5E0590	Strap guide cover		1
30	A68AB-5E0569	HN 4mm		1
31	A68AB-5E0575	Spring		1
32	A68AB-5E0574	HBS 5x25		1
33	A68AB-5E0580	HBS 4x12		2
34	A68AB-5E0562	FMS 5x30		1
35	A68AB-5E0592	Self-loading feeding leveler		1
36	A68AB-5E0591-1	Lower strap guide	(5~6mm)	1
	A68AB-5E0591-2	Lower strap guide	(9mm)	1
37	A68AB-5E0531	Bearing 605		1
38	A68AB-5E0530	Idle roller		1

Arch Unit

9.4

Fig.-1F-AB

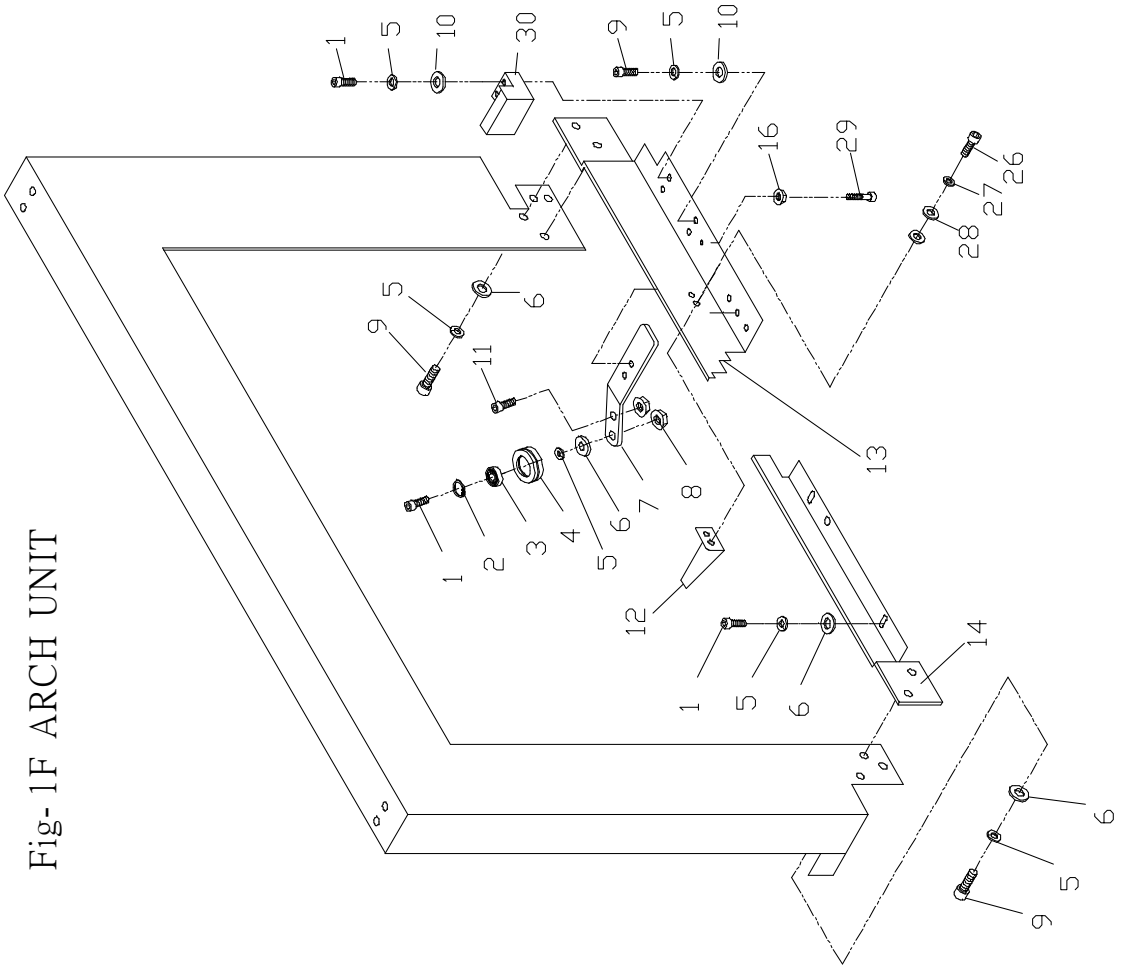


Fig- 1F ARCH UNIT

Fig.-1F-AB Arch Unit

No.	Part No.	Part Name	Part Name	Quantity
1	A68-1F0656	HBS 5x15		3
2	A68-1F0667	RR		1
3	A68-1F0607	Bearing 635		2
4	A68-1F0608	Pulley		2
5	A68-1F0660	SW 5mm		10
6	A68-1F0662	PW 5mm(15)		7
7	A68-1F0609	Pulley fix bracket		1
8	A68-1F0665	FLG 5mm		5
9	A68-1F0654	HBS 5x10		8
10	A68-1F0663	PW 5mm		4
11	A68-1F0655	HBS 5x12		2
12	A68-1F0610	Strap guide fix plate		1
13	A68AB-1F0606-1	Strap guide plate – right	(W650)	1
	A68AB-1F0606-2	Strap guide plate – right	(W850)	1
14	A68AB-1F0605-1	Strap guide plate – left	(W650)	1
	A68AB-1F0605-2	Strap guide plate – left	(W850)	1
16	A68-1F0664	FLG 4mm		2
26	A68-1F0651	HBS 4x8		2
27	A68-1F0658	SW 4mm		2
28	A68-1F0659	PW 4mm		2
29	A68-1F0669	HBS 4x25		1
30	A68-1F0618	Aluminum block		1

Arch Unit

9.4

Fig.-2F

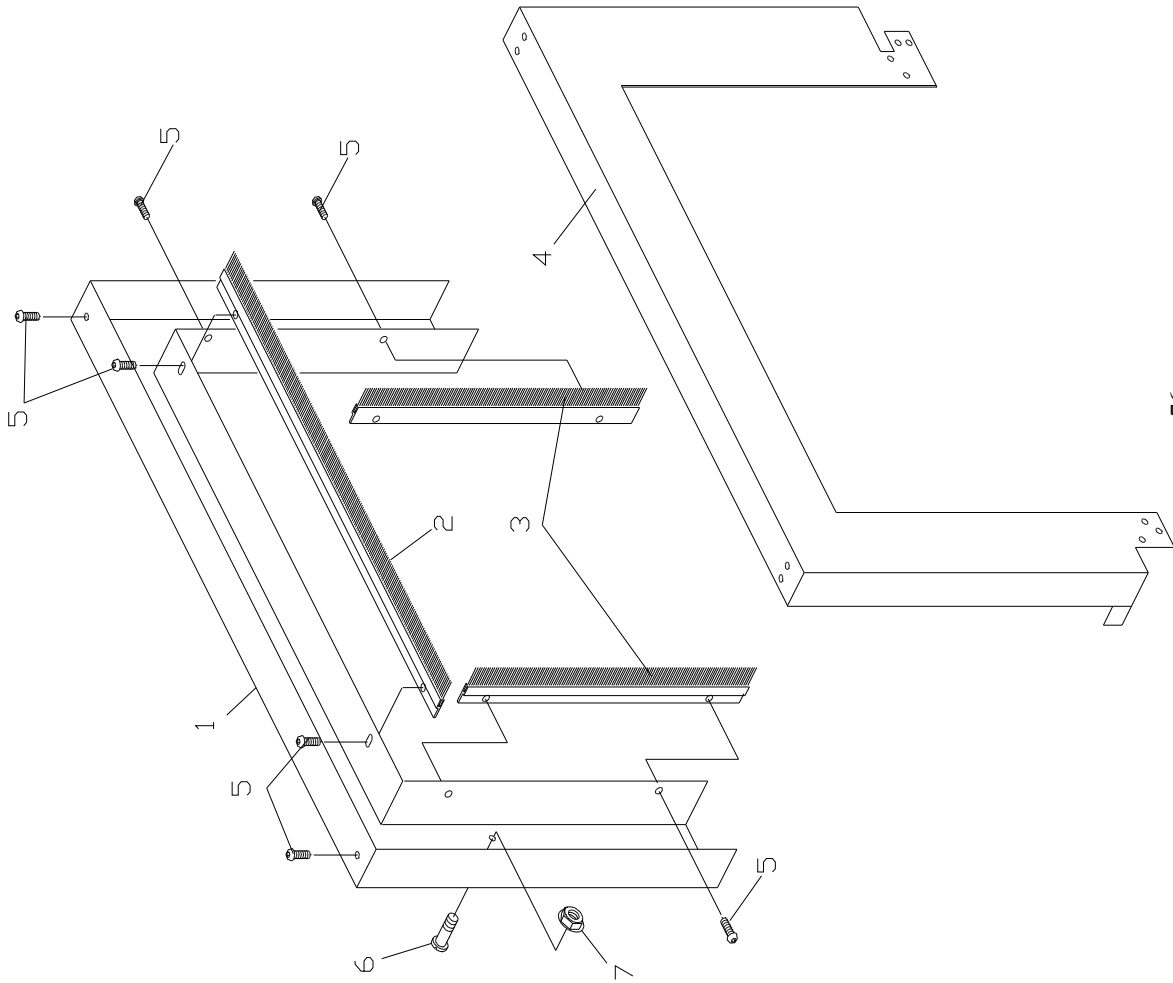


Fig.-2F Arch Unit

No.	Part No.	Part Name	Part Name	Quantity
1	A68AB-2F0601-1	Arch cover – rear	(W650*H400mm)	1
	A68AB-2F0601-2	Arch cover – rear	(W650*H600mm)	1
	A68AB-2F0601-3	Arch cover – rear	(W650*H800mm)	1
	A68AB-2F0601-4	Arch cover – rear	(W650*H1200mm)	1
	A68AB-2F0601-5	Arch cover – rear	(W850*H400mm)	1
	A68AB-2F0601-6	Arch cover – rear	(W850*H600mm)	1
	A68AB-2F0601-7	Arch cover – rear	(W850*H800mm)	1
	A68AB-2F0601-8	Arch cover – rear	(W850*H1200mm)	1
2	A68-2F0602-1	Brush on top arch	(W650mm)	1
	A68-2F0602-2	Brush on top arch	(W850mm)	1
3	A68-2F0603-1	Brush of side arch	(H400mm)	2
	A68-2F0603-2	Brush of side arch	(H600mm)	2
	A68-2F0603-3	Brush of side arch	(H800mm)	2
	A68-2F0603-4	Brush of side arch	(H1200mm)	2
4	A68AB-2F0604-1	Arch cover – front	(W650*H400mm)	1
	A68AB-2F0604-2	Arch cover – front	(W650*H600mm)	1
	A68AB-2F0604-3	Arch cover – front	(W650*H800mm)	1
	A68AB-2F0604-4	Arch cover – front	(W650*H1200mm)	1
	A68AB-2F0604-5	Arch cover – front	(W850*H400mm)	1
	A68AB-2F0604-6	Arch cover – front	(W850*H600mm)	1
	A68AB-2F0604-7	Arch cover – front	(W850*H800mm)	1
	A68AB-2F0604-8	Arch cover – front	(W850*H1200mm)	1
5	A68-2F0653	THS 5x10		10
6	A68-2F0668	Control Board Hanger		1

SV5000C

Fig.-2F Arch Unit

No.	Part No.	Part Name	Part Name	Quantity
7	A68-2F0670	FLG 8mm		1

Arch Unit

9.4

Fig.-1G

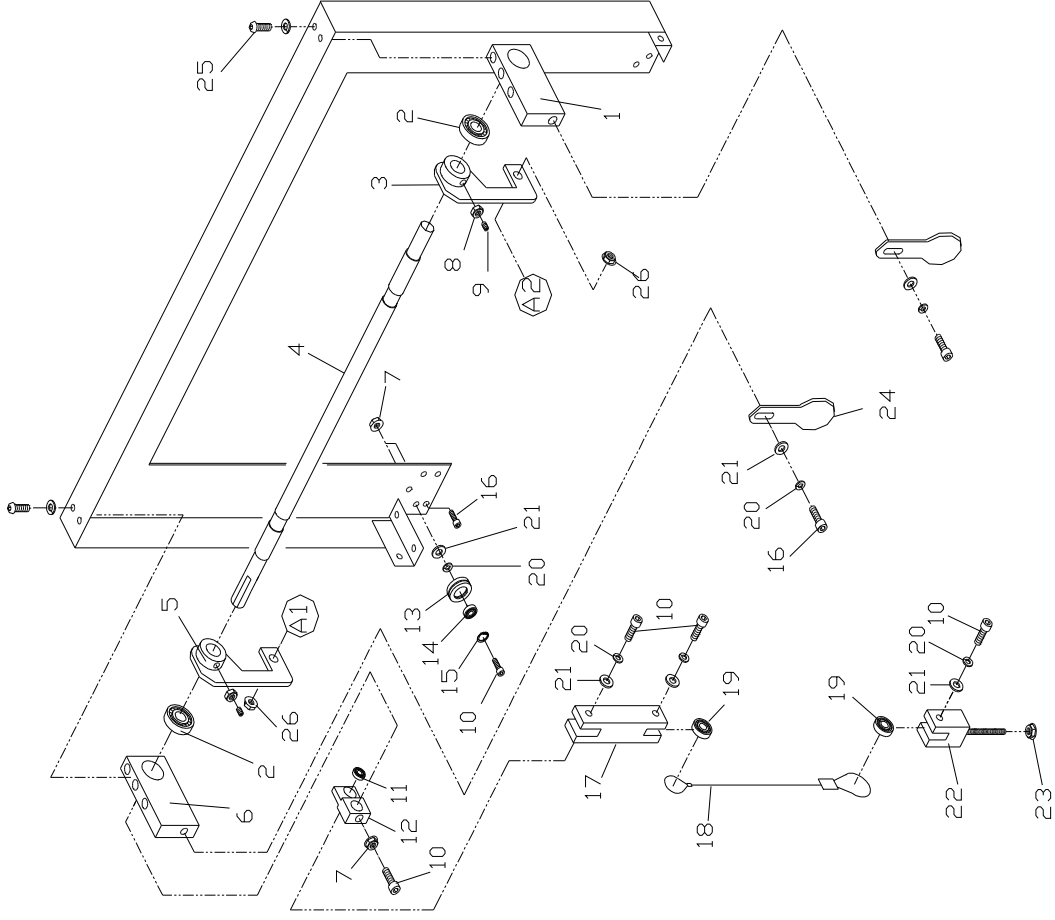


Fig.-1G Arch Unit

No.	Part No.	Part Name	Part Name	Quantity
1	A68-1G0701-1	Bracket for connecting rod	(5~6mm)	1
	A68-1G0701-2	Bracket for connecting rod	(9mm)	1
2	A68-1G0702	Bearing	6800	2
3	A68-1G0703	Strap guide fixing plate		1
4	A68AB-1G0704-1	Connecting rod shaft	(650mm)	1
	A68AB-1G0704-1	Connecting rod shaft	(850mm)	1
5	A68-1G0705	Strap guide fixing plate - left		1
6	A68-1G0706-1	Connect rod bracket – left	(5~6mm)	1
	A68-1G0706-2	Connect rod bracket – left	(9mm)	1
7	A68-1G0764	FLG 5mm		3
8	A68-1G0763	HN 5mm		2
9	A68-1G0759	HSS 5x16		2
10	A68-1G0756	HBS 5x15		5
11	A68-1G0707	Bearing		1
12	A68-1G0708	Link		1
13	A68-1G0716	Pulley		1
14	A68-1G0717	Bearing 635		1
15	A68-1G0765	RR		1
16	A68-1G0755	HBS 5x12		3
17	A68-1G0709	Connecting rod		1

Fig.-1G Arch Unit

No.	Part No.	Part Name	Part Name	Quantity
18	A68AB-1G0710-1	Wire rob	(W650*H400mm)	1
	A68AB-1G0710-2	Wire rob	(W650*H600mm)	1
	A68AB-1G0710-3	Wire rob	(W650*H800mm)	1
	A68AB-1G0710-4	Wire rob	(W650*H1200mm)	1
	A68AB-1G0710-5	Wire rob	(W850*H400mm)	1
	A68AB-1G0710-6	Wire rob	(W850*H600mm)	1
	A68AB-1G0710-7	Wire rob	(W850*H800mm)	1
	A68AB-1G0710-8	Wire rob	(W850*H1200mm)	1
19	A68-1G0711	Bearing 605		2
20	A68-1G0760	SW 5mm		6
21	A68-1G0761	PW 5mm		6
22	A68-1G0721	Cable wire		1
23	A68-1G0767	FLG 6mm		1
24	A68-1G0712	Auxiliary fasten plate		2
25	A68-1G0753	THS 5x10		4
26	A68-1G0768	Spacer 5mm		2

Arch Unit

9.4

Fig.-2G-AB

Fig-2G ARCH UNIT

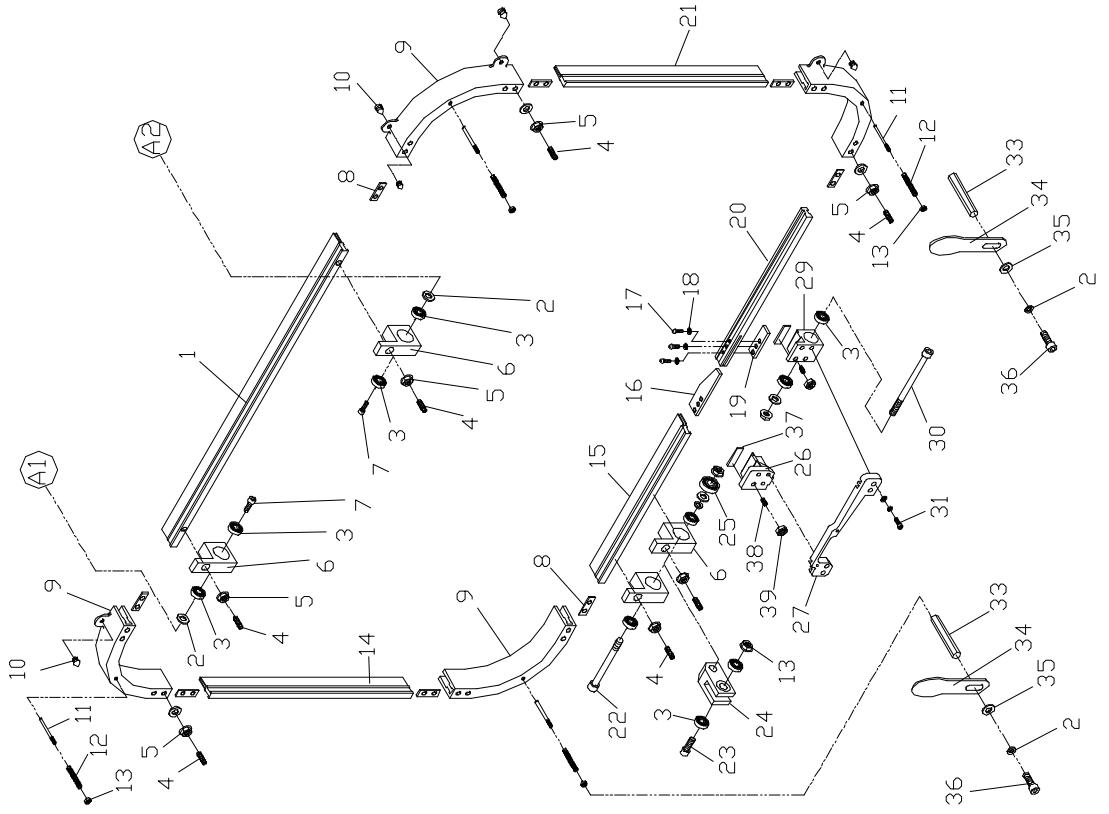


Fig.-2G-AB Arch Unit

No.	Part No.	Part Name	Part Name	Quantity
1	A68AB-2G0732-1	Strap guide (upper)	(W650)(5~6mm)	1
	A68AB-2G0732-2	Strap guide (upper)	(W650)(9mm)	1
	A68AB-2G0732-3	Strap guide (upper)	(W850)(5~6mm)	1
	A68AB-2G0732-4	Strap guide (upper)	(W850)(9mm)	1
2	A68-2G0760	SW 5mm		7
3	A68-2G0718	Bearing 605		10
4	A68-2G0759	HSS 5x16		20
5	A68-2G0764	FLG 5mm		20
6	A68-2G0719	Chute connecting rod		4
7	A68-2G0757	HBS 5x25		2
8	A68-2G0724	Chute fix plate		8
9	A68-2G0715	Chute connecting plate		4
10	A68-2G0731	Rubber plate		8
11	A68-2G0714	Chute		4
12	A68-2G0713	Spring		4
13	A68-2G0768	Spacer 5mm		5
14	A68AB-2G0720-1	Strap guide (left)	(H400mm)(5~6mm)	1
	A68AB-2G0720-2	Strap guide (left)	(H400mm)(9mm)	1
	A68AB-2G0720-3	Strap guide (left)	(H600mm)(5~6mm)	1
	A68AB-2G0720-4	Strap guide (left)	(H600mm)(9mm)	1
	A68AB-2G0720-5	Strap guide (left)	(H800mm)(5~6mm)	1
	A68AB-2G0720-6	Strap guide (left)	(H800mm)(9mm)	1

Fig.-2G-AB Arch Unit

No.	Part No.	Part Name	Part Name	Quantity
15	A68AB-2G0725-1	Strap guide (left, bottom)	(W650) (5~6mm)	1
	A68AB-2G0725-2	Strap guide (left, bottom)	(W650) (9mm)	1
	A68AB-2G0725-3	Strap guide (left, bottom)	(W850) (5~6mm)	1
	A68AB -2G0725-4	Strap guide (left, bottom)	(W850) (9mm)	1
16	A68-2G0728	Strap width adjust plate		1
17	A68-2G0751	PMS 4x8		3
18	A68-2G0769	SW 4mm		3
19	A68-2G0726	Strap width adjust plate		1
20	A68AB-2G0729-1	Strap guide (right, bottom)	(W650) (5~6mm)	1
	A68AB-2G0729-2	Strap guide (right, bottom)	(W650) (9mm)	1
	A68AB-2G0729-3	Strap guide (right, bottom)	(W850) (5~6mm)	1
	A68AB-2G0729-4	Strap guide (right, bottom)	(W850) (9mm)	1
21	A68AB-2G0730-1	Strap guide (right)	(H400) (5~6mm)	1
	A68AB-2G0730-2	Strap guide (right)	(H400) (9mm)	1
	A68AB-2G0730-3	Strap guide (right)	(H600) (5~6mm)	1
	A68AB-2G0730-4	Strap guide (right)	(H600) (9mm)	1
	A68AB-2G0730-5	Strap guide (right)	(H800) (5~6mm)	1
	A68AB-2G0730-6	Strap guide (right)	(H800) (9mm)	1
22	A68-2G0758	HBS 5x100		1
23	A68-2G0770	HBS 5x30		1
24	A68-2G0723	Swing block		1
25	A68-2G0717	Bearing 635		1
26	A68-2G0733	Left		1

Fig.-2G-AB Arch Unit

No.	Part No.	Part Name	Part Name	Quantity
27	A68AB-2G0735	Link		1
29	A68-2G0734	Right		1
30	A68-2G0766	HBS 5x40		1
31	A68-2G0756	HBS 5x15		4
32	A68-2G0775	HBS 4x8		2
33	A68-2G0722	Hexagon shaft		2
34	A68-2G0712	Auxiliary fasten plate		2
35	A68-2G0761	PW 5mm		6
36	A68-2G0755	HBS 5x12		2
37	A68-2G0776	Iron Sheet		2
38	A68-2G0777	HSS 5x10		4
39	A68-2G0778	Stops the slippery cap nut		4

Body Unit

9.5

Fig.-6H-AB

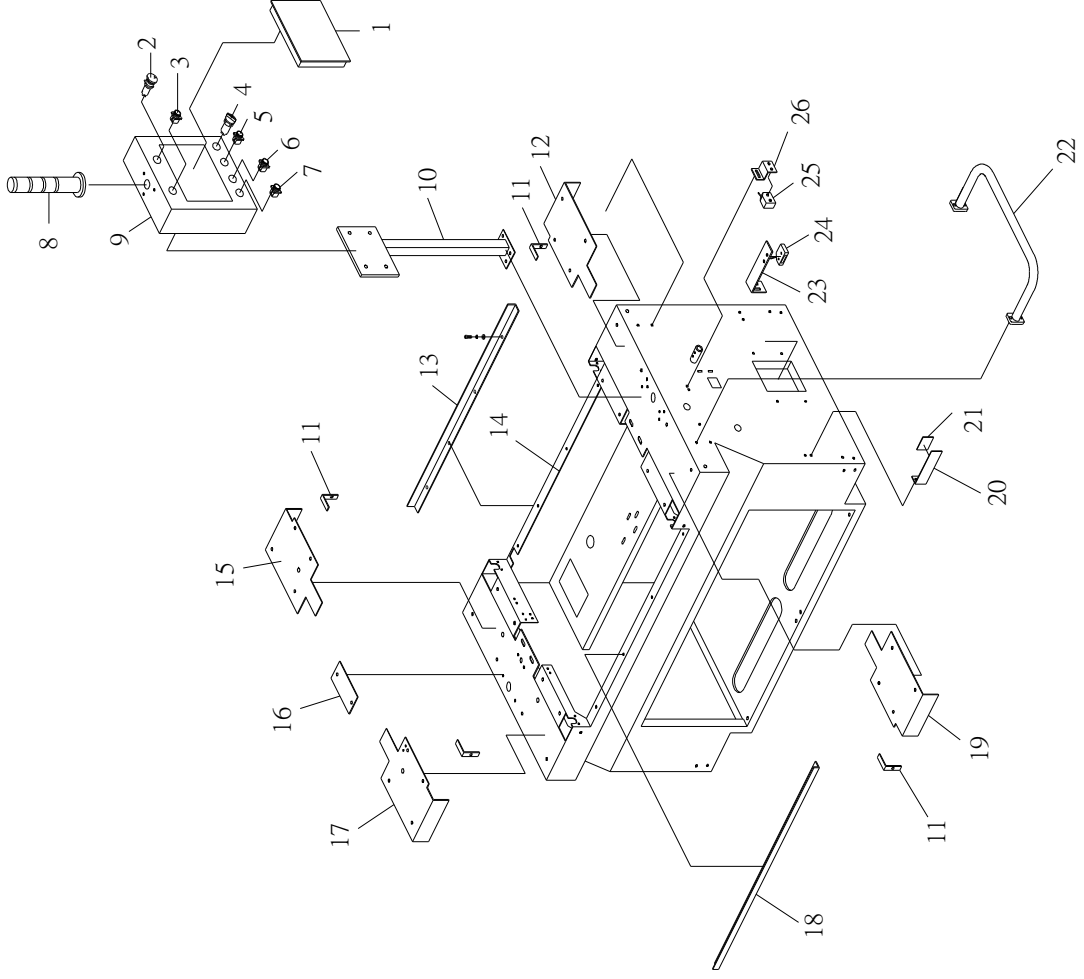


Fig.-6H-AB **Body Unit**

No.	Part No.	Part Name	Part Name	Quantity
1	A68AB-6H08152	HMI touch screen 7”		1
2	A68AB-6H08150	E-Stop		1
3	A68AB-6H08151	Push button - white		1
4	A68AB-6H08155	Select Switch		1
5	A68AB-6H08156	Push Button - orange		1
6	A68AB-6H08157	Push Button – Green		1
7	A68AB-6H08158	Push Button – yellow		1
8	A68AB-6H08148	Stack Light		1
9	A68AB-6H08149	Operating Panel		1
10	A68AB-6H08159	Bracket		1
11	A68AB-6H08172	Cover		1
12	A68AB-6H08182	Rear right cover		1
13	A68AB-6H08146-1	Rear cover	(W650mm)	1
	A68AB-6H08146-2	Rear cover	(W850mm)	1
14	A68AB-6H08145-1	Frame	(W650mm)	1
	A68AB-6H08145-2	Frame	(W850mm)	1
15	A68AB-6H08181	Rear left cover		1
16	A68AB-6H08180	Centre left cover		1
17	A68AB-6H08174	Front left cover		1
18	A68AB-6H08147-1	Front cover	(W650mm)	1
	A68AB-6H08147-2	Front cover	(W850mm)	1
19	A68AB-6H08169	Front right cover		1
20	A68AB-6H08168	Low Strap Sensor Bracket		1
21	A68AB-6H08167	Reflector		1

2012.02

Fig.-6H-AB **Body Unit**

No.	Part No.	Part Name	Part Name	Quantity
22	A68AB-6H08185	Handle		1
23	A68AB-6H08166	Low Strap Sensor Bracket		1
24	A68AB-6H08127	Low Strap Photocell		1
25	A68AB-6H08101	Empty Strap Sensor		1
26	A68AB-6H08165	Sensor Bracket		1

Body Unit

9.5

Fig.-7H-AB

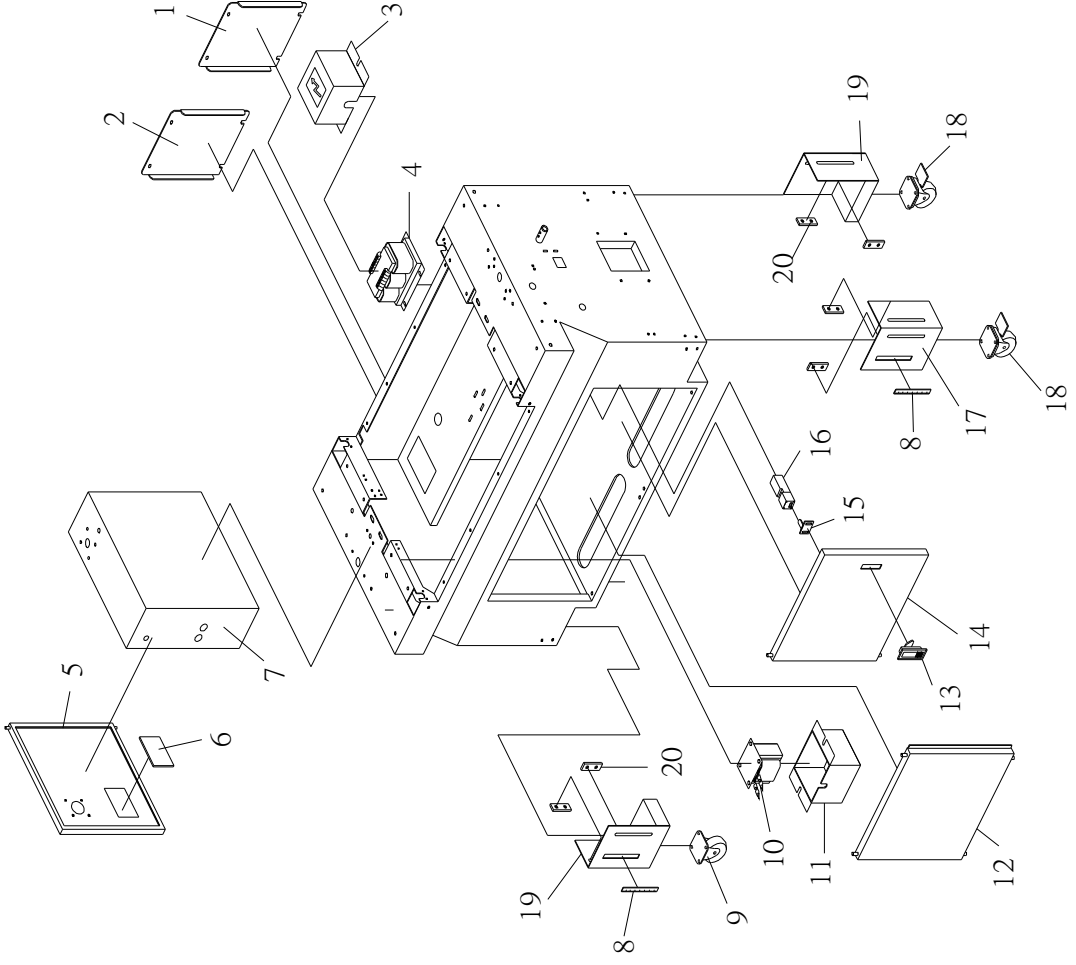


Fig.-7H-AB **Body Unit**

No.	Part No.	Part Name	Part Name	Quantity
1	A68AB-7H08183-1	Right Rear Cover	(W650mm)	1
	A68AB-7H08183-2	Right Rear Cover	(W850mm)	1
2	A68AB-7H08184-1	Left Rear Cover	(W650mm)	1
	A68AB-7H08184-2	Left Rear Cover	(W850mm)	1
3	A68AB-7H08136	Cover		1
4	A68AB-7H08135	Transformer		1
5	A68AB-7H08178	Electrical Control Box Door		1
6	A68AB-7H08177	Acrylic		1
7	A68AB-7H08179	Electrical Control Box		1
8	A68AB-7H08160	Table Height Indicator		4
9	A68AB-7H08164	Caster		2
10	A68AB-7H0804	Heater Transformer		1
11	A68AB-7H0805	Transformer Cover		1
12	A68AB-7H08153-1	Front Door (Left)	(W650mm)	1
	A68AB-7H08153-2	Front Door (Left)	(W850mm)	1
13	A68AB-7H0813	Latch		1
14	A68AB-7H08154-1	Front Door (Right)	(W650mm)	1
	A68AB-7H08154-2	Front Door (Right)	(W850mm)	1
15	A68AB-7H0814	Safety Switch Key		1
16	A68AB-7H0815	Safety Switch		1
17	A68AB-7H08161	Right Adjustable Led		2
18	A68AB-7H08163	Caster with Brake		2
19	A68AB-7H08162	Left Adjustable Led		2
20	A68AB-7H0887	Fasten Plate		8

Body Unit

9.5

Fig.-8H-AB

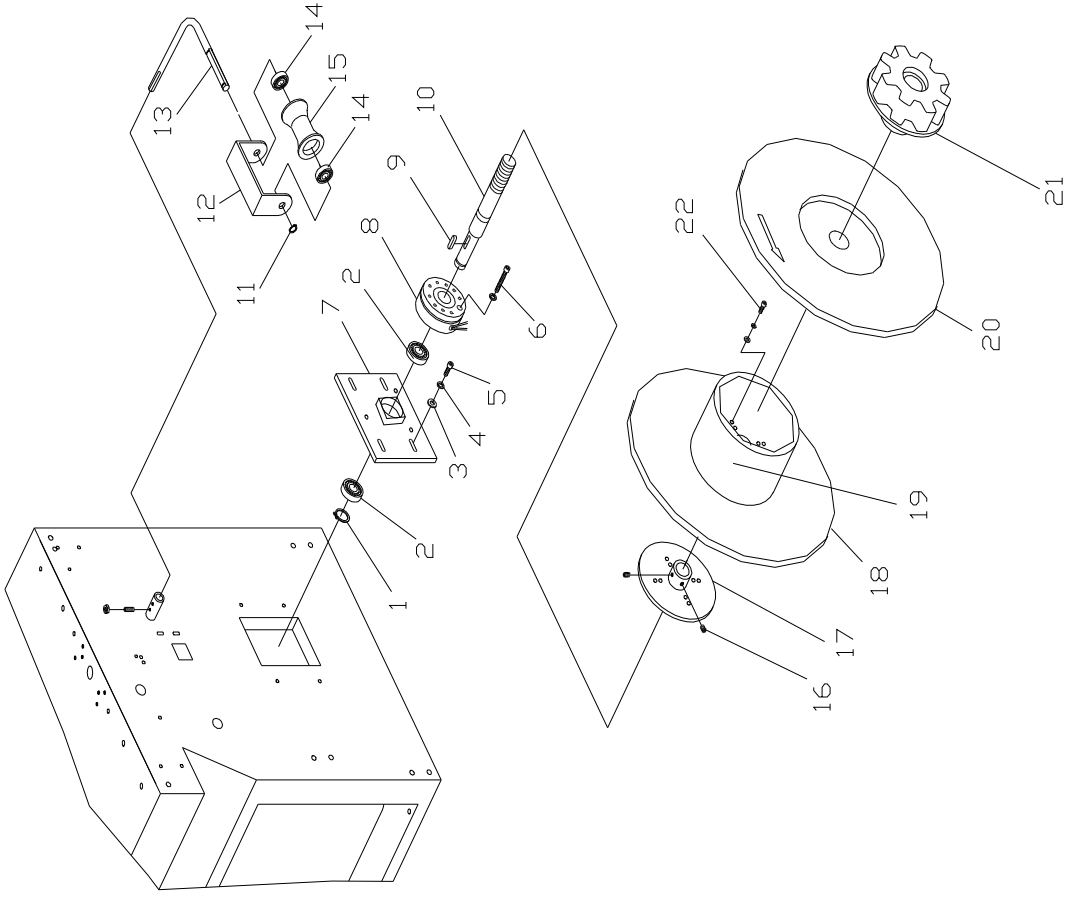


Fig.-8H-AB **Body Unit**

No.	Part No.	Part Name	Part Name	Quantity
1	A68AB-8H0866	SR-12		1
2	A68AB-8H0834	Bearing 6002		2
3	A68AB-8H0862	PW 6mm (19)		4
4	A68AB-8H0861	SW 6mm		4
5	A68AB-8H0857	HBS 6x16		4
6	A68AB-8H0873	HBS 6x33		3
7	A68AB-8H0886	Magnetic Brake Bracket		1
8	A68AB-8H0832	Magnetic Brake		1
9	A68AB-8H0865	KYA 5x15		1
10	A68AB-8H0885	Shaft		1
11	A68AB-8H0867	SR-8		1
12	A68AB-8H0890	Roller Holder		1
13	A68AB-8H0889	Arm		1
14	A68AB-8H0842	Ball Bearing 628		2
15	A68AB-8H8343	Idle Roller		1
16	A68AB-8H0855	HSS 6x10		2
17	A68AB-8H0882	Dispenser Bracket		1
18	A68AB-8H0883	Dispenser Flange (Flat)		1
19	A68AB-8H0884	Dispenser Inner Ring		1
20	A68AB-8H0829	Dispenser Flange		1
21	A68AB-8H0830	Dispenser Handle		1
22	A68AB-8H08111	HBS 6x10		8

Body Unit

9.5

Fig.-9H-AB

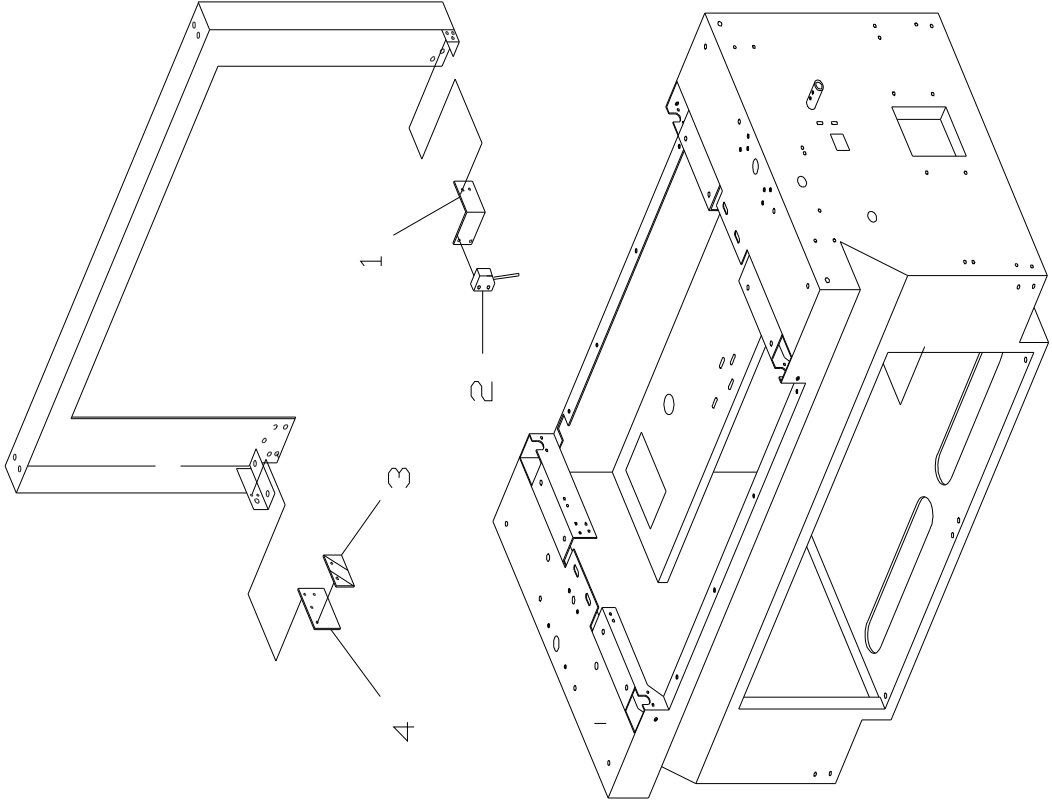


Fig.-9H-AB **Body Unit**

No.	Part No.	Part Name	Part Name	Quantity
1	A68AB-9H08175	Photocell Bracket		1
2	A68AB-9H08176	Photocell for Strapping position		1
3	A68AB-9H08171	Reflector		1
4	A68AB-9H08170	Reflector Bracket		1

Control Box Unit

9.6

Fig.-2J-AB

Fig-2J-AB CONTROL BOX UNIT

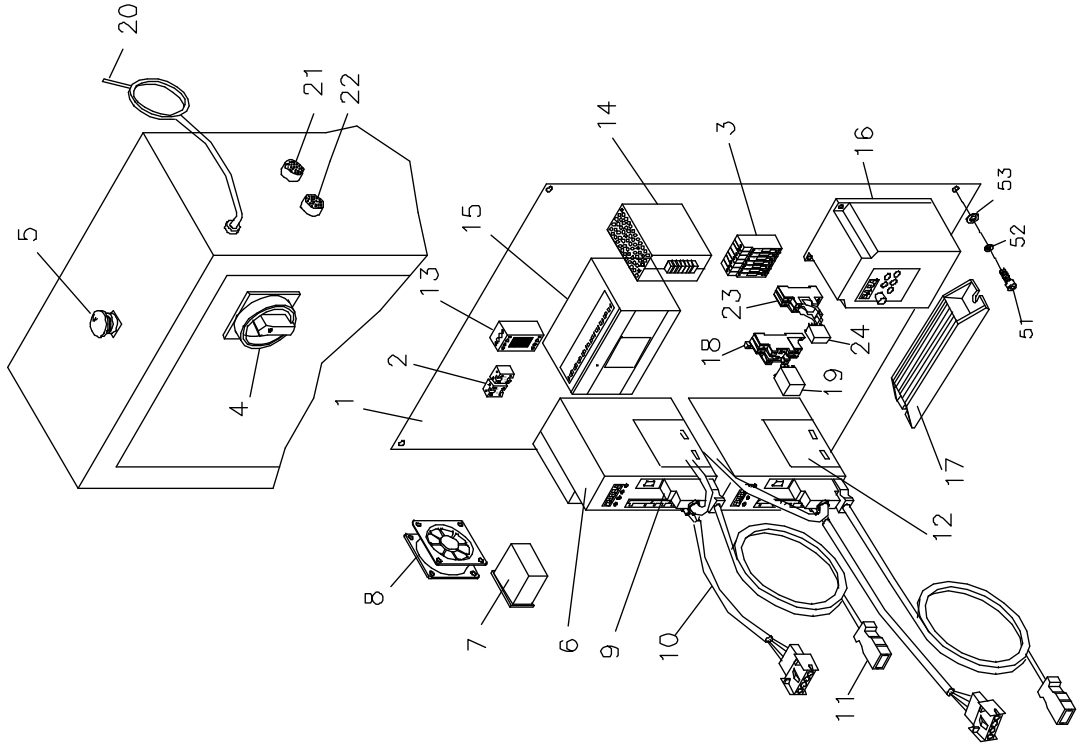


Fig.-2J-AB Control Box Unit

No.	Part No.	Part Name	Part Name	Quantity
1	A68AB-2J0901	Control Box Bottom Plate		1
2	A68AB-2J0930	SSR		2
3	A68AB-2J0926	Fuse		8
4	A68AB-2J0928	Power Switch		1
5	A68AB-2J0929	Stop Button		1
6	A68AB-2J0906-1	Cam Shaft Servo Driver (see Appendix A)	Yaskawa (old), until August 30th, 2010	1
	A68AB-2J0906-2	Cam Shaft Servo Driver (see Appendix A)	Yaskawa (new), September, 2010 - present	1
7	A68AB-2J0907	Counter		1
8	A68AB-2J0908	Fan		1
9	A68AB-2J0909	Connector (PCB and Driver)		2
10	A68AB-2J0910	Servo power Cord		2
11	A68AB-2J0911	Servo Signal Cable		2
12	A68AB-2J0912-1	Feed Re-tracking Servo Driver (see Appendix A)	Yaskawa (old), until August 30th, 2010	1
	A68AB-2J0912-2	Feed Re-tracking Servo Driver (see Appendix A)	Yaskawa (new), September, 2010 - present	1
13	A68AB-2J0913	Magnet Contactor		1
14	A68AB-2J0914	Power Supply		1
15	A68AB-2J0915	PLC		1
16	A68AB-2J0923	Inverter		1
17	A68AB-2J0924	Resistance for Clutch Braking		1
18	A68AB-2J0935	Relay base		1

Fig.-2J-AB Control Box Unit

No.	Part No.	Part Name	Part Name	Quantity
19	A68AB-2J0936	Relay (Omron, LY2N-J)		8
20	A68AB-2J0925	Power Cord		1
21	A68AB-2J0933	External Connector socket -1		1
22	A68AB-2J0934	External Connector Socket 2		1
23	A68AB-2J0937	Relay Base		2
24	A68AB-2J0938	Relay IDEC (RJ2S-CL-D24)		2
51	A68AB-2J0951	HBS 6x15		4
52	A68AB-2J0952	SW 6mm		4
53	A68AB-2J0953	PW 6mm		4

Belt Driving Table Top Assembly

Fig.-1K-AB

Fig- 1K-AB

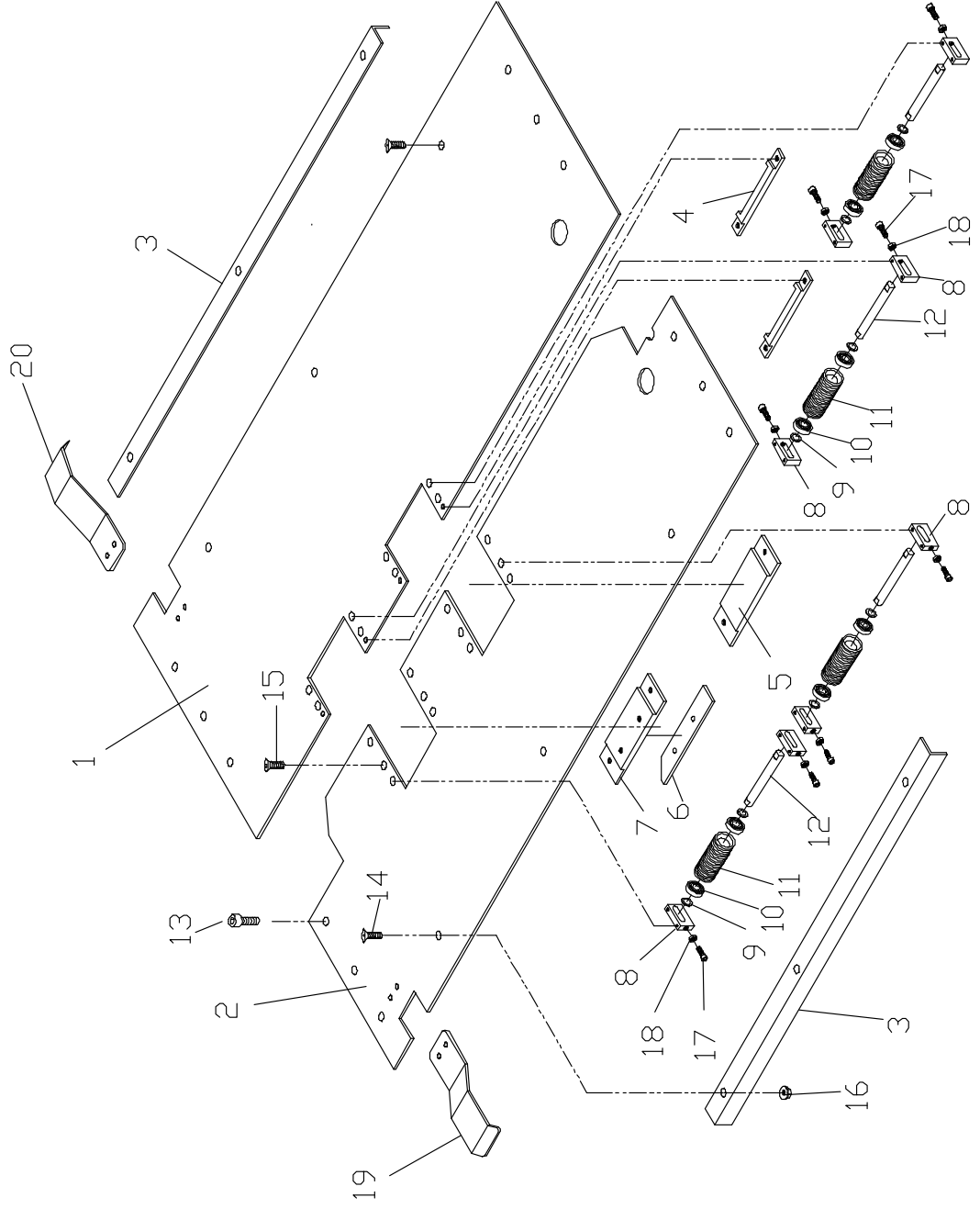


Fig.-1K-AB Belt Driving Table Top Assembly

No.	Part No.	Part Name	Part Name	Quantity
1	A68AB-1K1001-1	Rear Cover	(W650mm)	1
	A68AB-1K1001-2	Rear Cover	(W850mm)	1
2	A68AB-1K1002-1	Front Cover	(W650mm)	1
	A68AB-1K1002-2	Front Cover	(W850mm)	1
3	A68AB-1K1003-1	Top Plate Reinforce	(W650mm)	2
	A68AB-1K1003-2	Top Plate Reinforce	(W850mm)	2
4	A68AB-1K1039	Rear Cover Plate		1
5	A68AB-1K1040	Front Cover Plate		1
6	A68AB-1K1041	Strap width Adjustment Assembly		1
7	A68AB-1K1042	Front Cover Plate		1
8	A68AB-1K1008	Shaft Bracket		8
9	A68AB-1K1009	Washer		8
10	A68AB-1K1010	Ball Bearing		8
11	A68AB-1K1043	Multi Groove Front Roller		4
12	A68AB-1K1044	Shaft		4
13	A68AB-1K1051	HBS 5x25		4
14	A68AB-1K1053	5x12 FMS		12
15	A68AB-1K1052	5x8 FMS		28
16	A68AB-1K1055	FLG 5mm		12
17	A68AB-1K1060	HBS 5x30		8
18	A68AB-1K1054	HN 5mm		8
19	A68AB-1K1066	Front Cover Plate		1
20	A68AB-1K1067	Rear Cover Plate		1

Belt Driving Table Top Assembly

9.7

Fig.-2K-AB

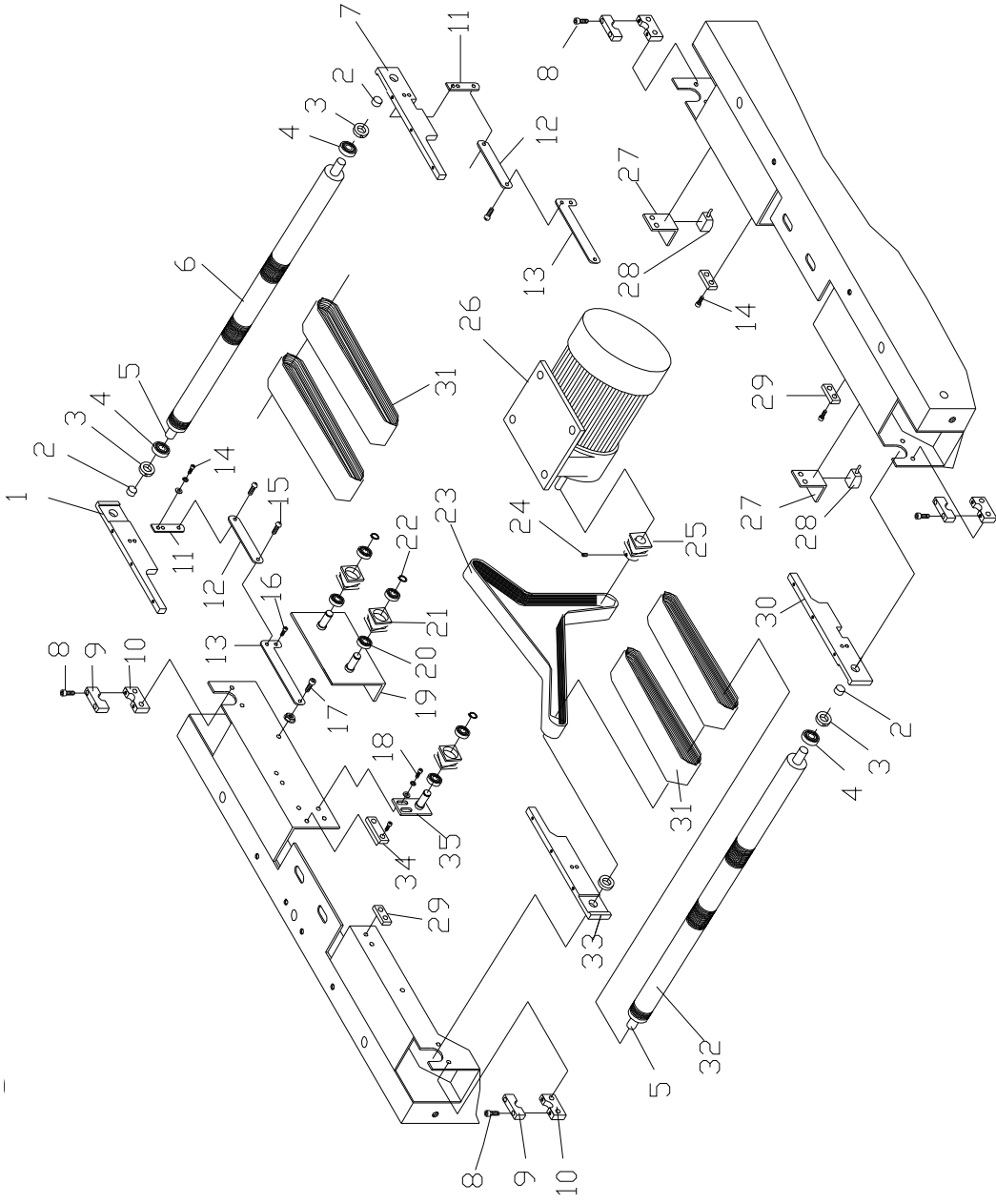


Fig.-2K-AB Belt Driving Table Top Assembly

No.	Part No.	Part Name	Part Name	Quantity
1	A68AB-2K1024	Base Frame		1
2	A68AB-2K1030	Sleeve Bearing MB2010		4
3	A68AB-2K1029	Fixed Collar		4
4	A68AB-2K1028	Bearing 6004		4
5	A68AB-2K1031	Shaft		2
6	A68AB-2K1027-1	Rear Belt Driving Roller	(W650mm)	1
	A68AB-2K1027-2	Rear Belt Driving Roller	(W850mm)	1
7	A68AB-2K1026	Rear Aluminum Basket		1
8	A68AB-2K1056	HBS 6x20		8
9	A68AB-2K1014	Shaft Collar		4
10	A68AB-2K1013	Shaft Base		4
11	A68AB-2K1060	Puller 1		4
12	A68AB-2K1061	Puller 2		4
13	A68AB-2K1062	Puller 3		4
14	A68AB-2K1058	HBS 5x15		8
15	A68AB-2K1063	THS 5x10		8
16	A68AB-2K1064	HBS 4x8		4
17	A68AB-2K1065	HBS 5x25		4
18	A68AB-2K1057	HBS 6x16		6
19	A68AB-2K1017	Pulley Guide Base		1
20	A68AB-2K1018	Ball Bearing 6002		6
21	A68AB-2K1019	Pulley		3
22	A68AB-2K1020	SR-12		3

Fig.-2K-AB Belt Driving Table Top Assembly

No.	Part No.	Part Name	Part Name	Quantity
23	A68AB-2K1045	Transmission Belt 9-73'		1
24	A68AB-2K1059	HSS 6x10		2
25	A68AB-2K1038	Motor Pulley (Grooved)		1
26	A68AB-2K1037	Reducing Motor		1
27	A68AB-2K1035	Proximity Switch Bracket		2
28	A68AB-2K1036	Proximity Switch		2
29	A68AB-2K1021	Table Plate Frame Bracket		4
30	A68AB-2K1025	Front Aluminum Base Frame		1
31	A68AB-2K1046	Table Top driving Belt 59-24'		4
32	A68AB-2K1047-1	Front Belt Roller	(W650mm)	1
	A68AB-2K1047-2	Front Belt Roller	(W850mm)	1
33	A68AB-2K1023	Front Left Aluminum Base Frame		1
34	A68AB-2K1022	Adjustment Base Frame		1
35	A68AB-2K1016	Belt Guiding Roller Bracket		1

Pneumatic Assembly (if equipped)

9.8

Fig.-1L-AB

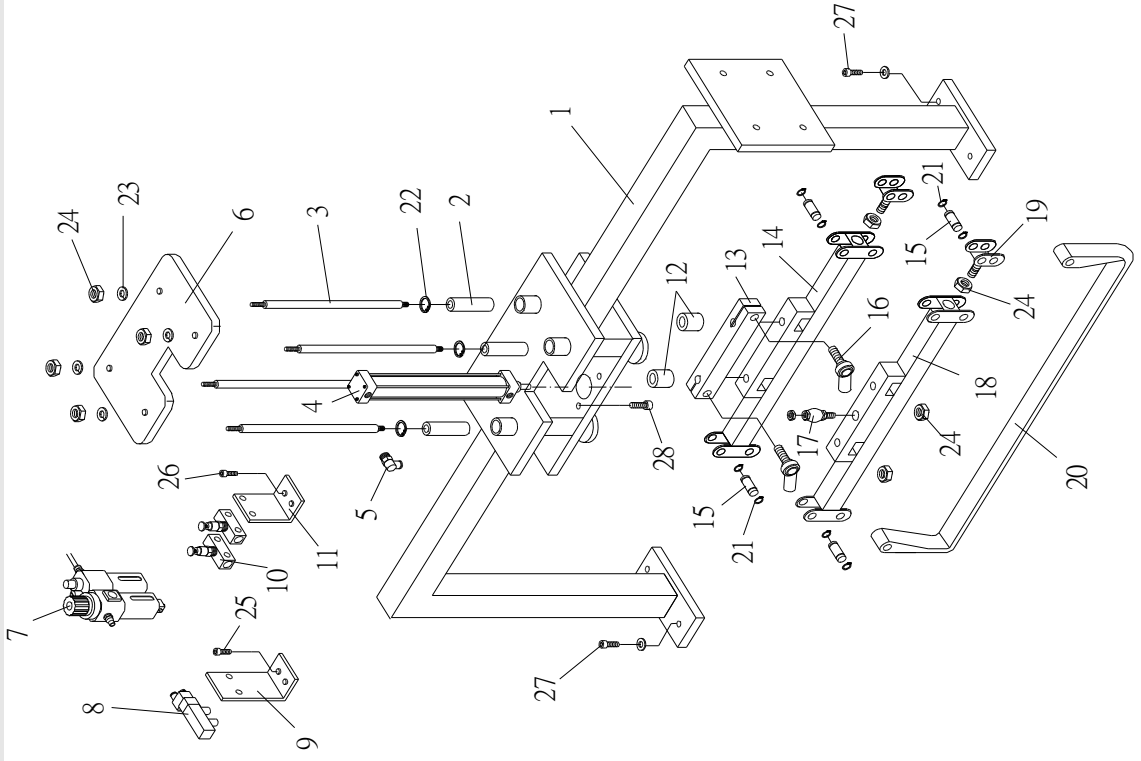


Fig.-1L-AB Pneumatic Assembly



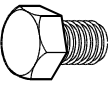
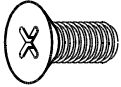
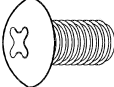

No.	Part No.	Part Name	Part Name	Quantity
1	A68AB-1L1101-1	Frame	(W650mm)	1
	A68AB-1L1101-2	Frame	(W850mm)	1
2	A68AB-1L1102	Bearing		4
3	A68AB-1L1103-1	Guiding Rod	(H400mm)	4
	A68AB-1L1103-2	Guiding Rod	(H600mm)	4
	A68AB-1L1103-3	Guiding Rod	(H800mm)	4
	A68AB-1L1103-4	Guiding Rod	(H1200mm)	4
4	A68AB-1L1104-1	Cylinder	(H400mm)	1
	A68AB-1L1104-2	Cylinder	(H600mm)	1
	A68AB-1L1104-3	Cylinder	(H800mm)	1
	A68AB-1L1104-4	Cylinder	(H1200mm)	1
5	A68AB-1L1105	Adaptor		2
6	A68AB-1L1106	Plate		1
7	A68AB-1L1107	Pressure gauge		1
8	A68AB-1L1108	Triad		1
9	A68AB-1L1109	Triad housing		1
10	A68AB-1L1110	Air vent valve		2
11	A68AB-1L1111	Air vent valve holder		1
12	A68AB-1L1112	Cushion rubber		2
13	A68AB-1L1113	Bracket		1
14	A68AB-1L1114-1	Pressure lever (back)	(W650mm)	1
	A68AB-1L1114-2	Pressure lever (back)	(W850mm)	1
15	A68AB-1L1115	Shaft		6
16	A68AB-1L1116	Screw M10		2

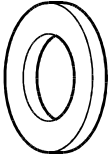
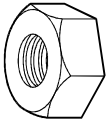
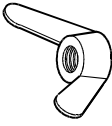
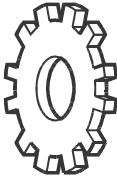




Fig.-1L-AB Pneumatic Assembly

No.	Part No.	Part Name	Part Name	Quantity
17	A68AB-1L1117	Cylinder adaptor		1
18	A68AB-1L1118-1	Pressure lever (front)	(W50mm)	1
	A68AB-1L1118-2	Pressure lever (front)	(W50mm)	1
19	A68AB-1L1119	Cloth rope holder		2
20	A68AB-1L1120-1	Cloth rope	(W50mm)	2
	A68AB-1L1120-2	Cloth rope	(W50mm)	2
21	A68AB-1L1121	R ring		12
22	A68AB-1L1122	Retaining ring		4
23	A68AB-1L1123	SW 14 mm		4
24	A68AB-1L1124	Screw cap M14		10
25	A68AB-1L1125	HBS 5 x 10		2
26	A68AB-1L1126	HBS 5 x 6		2
27	A68AB-1L1127	HBS 8 x 16		4
28	A68AB-1L1128	HBS 6 x 20		4

Screw Classification List

9.9

Shape	Classification	Name	Specification
	HBS	Hexagon Bot Screw	HBS M____*____
	HSS	Headless Set Screw	HSS M____*____
	HB	Hex.hd Blot	HB M____*____
	FMS	Flat M/C Screw	FMS M____*____
	TMS	Truss hd.M/C Screw	TMS M____*____
	PMS	Pan M/C Screw	PMS M____*____

Shape	Classification	Name	Specification
	PW	Plain Washer	PW M____
	HN	Hex. Nut	HN M____
	WN		WN M____
	TW		TW M____
		Stop Ring	H-____
		Stop Ring	S-____
		Stop Ring	E-____
		Spring Pin	SP Ø____

Part List And Drawings

9.10

Appendix A: Motor Application Phase

ATTENTION

As replacing the parts, motors at each application phase have their own corresponding drivers. Motor and driver has to be tied in the same brand. Different brands cannot be mutually shared. Be sure to check in advance its manufacture date as purchasing spare parts.

1. Motor

In previous version of operational manual, the part numbers of motors are listed as following:

A68-1A0103(servo motor);

A68-1D0401 (servo motor);

Because there is a big parts modification of motors, the part number of motors now is split into different numbers, corresponding different versions.

Old part No.	New Part No.	brand	Part Name	Quantity	Application Phase
A68-1A0103	A68-1A0103-1	Yaskawa (old)	servo motor	1	until August, 2010
A68-1D0401	A68-1D0401-1	Yaskawa (old)	servo motor	1	until August, 2010
A68-1A0103	A68-1A0103-2	Yaskawa (new)	servo motor	1	September, 2010 - present
A68-1D0401	A68-1D0401-2	Yaskawa (new)	servo motor	1	September, 2010 - present

** as demanding the motor, please check first the I.D. plate of the machine or present its serial number for checking its version.

2. Motor driver

In previous version of operational manual, the part number of motors is listed as following:

A68-2J0906 (cam shaft servo driver)

A68-2J0912 (feed re-tracking servo driver)

Because of the same reason of big parts modification of motors, the part number of motor drivers now is split into different numbers, corresponding its different versions.

Old part No.	New Part No.	Brand	Part Name	Quantity	Application Phase
A68AB-2J0912	A68AB-2J0912-1	Yaskawa (old)	feed re-tracking servo driver	1	until August, 2010
A68AB-2J0906	A68AB-2J0906-1	Yaskawa (old)	cam shaft servo driver	1	until August, 2010
A68AB-2J0912	A68AB-2J0912-2	Yaskawa (new)	feed re-tracking servo driver	1	September, 2010 - present
A68AB-2J0906	A68AB-2J0906-2	Yaskawa (new)	cam shaft servo driver	1	September, 2010 - present

** as demanding the motor, please check first the I.D. plate of the machine or present its serial number for checking its version.