

PC1500SS

POLYCHEM[®]
PLASTIC STRAPPING SYSTEMS

STAINLESS STEEL AUTOMATIC STRAPPING MACHINE



**UP TO
60
STRAPS PER
MINUTE!**

**304 STAINLESS STEEL
SPLASH DOWN MACHINE
(IP 54 RATING)**

Standard Adjustable Height Roller Top

- **For Meat, Fish and Poultry Markets**
- **German DC Brushless Motors**
- **Easy to Operate**



PC1500SS Stainless Steel Automatic Strapping Machine



The PC1500SS is a splash down, "side-seal strapping machine. It is manufactured with stainless steel frame and rust resistant or corrosion retardant parts inside. The water resistant design provides exceptional protection from moisture and splash down spray. The PC1500SS is

applicable in moist and harsh working environments such as meat/poultry processing plants and the marine food industry.



PC1500SS Control Panel

Dimensions

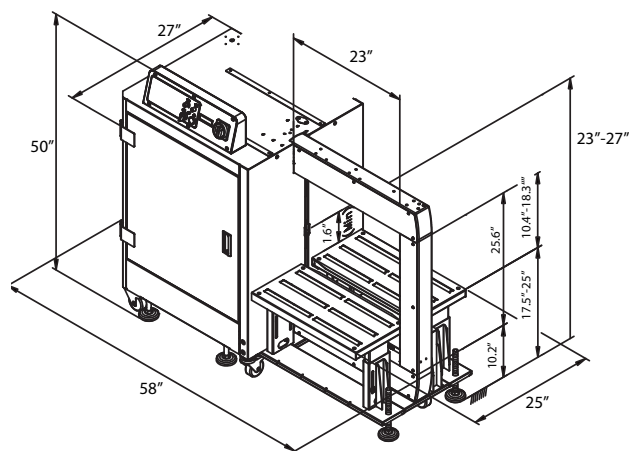

PC1500SS		WIDTH			
		23	31	33	39
HEIGHT	25				
	33				
	41				
	49				
	65				

Standard Arch Sizes

Specifications

Cycle Rate:	Up to 60 straps per minute
Standard Arch Sizes:	33"x23", 41"x31", 65"x39"
Minimum Package Size:	4"w x 4"h
Core Sizes:	8" x 8"
Package Weight:	Up to 100 lbs.
Strap Tension:	2-120 lbs.
Polypropylene Strap:	5mm, 6mm, 9mm, 12mm 1/4", 3/8", 1/2"
Electrical Requirements:	110V, 220V, 50/60Hz, 1PH
Optional:	Press, side pusher
Shipping Weight:	800 lbs.

Standard Features

- High strapping speed (up to 60 straps per minute)
- End of cycle and strapping error signals
- Various arch sizes
- Internal strap dispenser protects strap from water
- Water resistant design
- Internal heater to prevent moisture build up and accumulating humidity

Options

- Operator friendly low strap sensor (triple lamp)
- Vertical press bar (pneumatic)
- Available without adjustable roller table

NOTE: All throughput estimations vary with actual size, package size, and conveyor speed.



6277 HEISLEY ROAD
MENTOR, OHIO 44060
(440) 357-1500
FAX (440) 352-9553

WEST COAST DISTRIBUTION CENTER
11920 ALTAMAR PLACE
SANTA FE SPRINGS, CA 90670
(562) 903-4576
FAX (562) 903-4579
1-800-899-0822

CALL TOLL FREE 1-800-548-9557
www.polychem.com

