

PC1500

POLYCHEM[®]
PLASTIC STRAPPING SYSTEMS



AUTOMATIC STRAPPING MACHINE

**UP TO
60
STRAPS PER
MINUTE!**



- **German DC Brushless Motors**
- **Easy to Operate**
- **Adjustable Height Roller Top Standard**



PC1500 Automatic Strapping Machine



German DC Brushless Motors

The PC1500 is an innovative high speed automatic strapping machine. It is equipped with all industry standard features. The PC1500 offers optimal performance, high cycle speed and easy maintenance. The PC1500 is the same reliable

PC1000 strapping head in a side seal configuration. The side mounting prevents debris from contaminating the seal head. This machine is the most cost effective solution to your strapping requirements in its class today.



PC1500 Control Panel

Dimensions

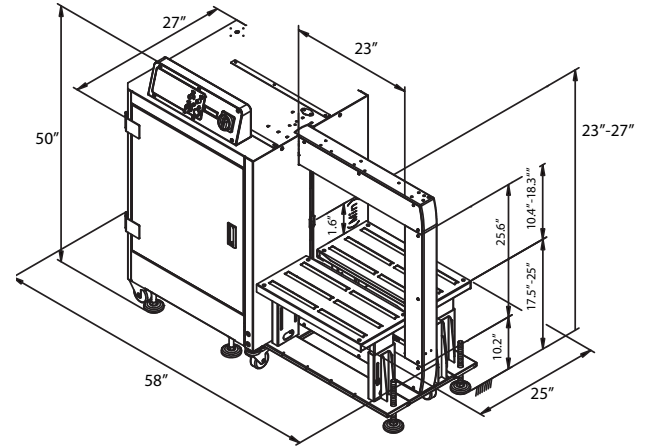

PC1500		WIDTH			
		23	31	33	39
HEIGHT	25				
	33				
	41				
	49				
	65				

Standard Arch Sizes

Standard Features

- German DC brushless motor technology
- Waist high quick change coil and strap feed
- Easy access operating control panel
- Multiple strap function
- Easy access strap chute-no tools required
- One piece strap chute
- Sensor controlled heater
- End of coil strap ejector/loop ejector
- Electronic brake / Auto loader
- Lockable casters
- Electronic tension control
- Smart LCD display

Specifications

Cycle Rate:	Up to 60 straps per minute
Standard Arch Sizes:	33"x23", 41"x31", 65"x39"
Minimum Package Size:	4" w x 4" h
Core Sizes:	8" x 8"
Package Weight:	Up to 100 lbs.
Strap Tension:	2-120 lbs.
Polypropylene Strap:	5mm, 6mm, 9mm, 12mm 1/4", 3/8", 1/2"
Electrical Requirements:	110V, 220V, 50/60Hz, 1PH
Optional:	Press, side pusher
Shipping Weight:	800 lbs.



CALL TOLL FREE 1-800-548-9557
www.polychem.com

6277 HEISLEY ROAD
MENTOR, OHIO 44060
(440) 357-1500
FAX (440) 352-9553

WEST COAST DISTRIBUTION CENTER
11920 ALTAMAR PLACE
SANTA FE SPRINGS, CA 90670
(562) 903-4576
FAX (562) 903-4579
1-800-899-0822

