

PC PRO

POLYCHEM[®]
PLASTIC STRAPPING SYSTEMS

AUTOMATIC STRAPPING MACHINE



**UP TO
60
STRAPS PER
MINUTE!**

- ***Full Feature Machine with a Basic Price***
- ***User Friendly Design/Full Colored Touch Screen Controls***
- ***Servo Technology Provides Ultimate Reliability***
- ***One Piece Track***



PC PRO Automatic Strapping Machine



The PC PRO Automatic Strapping Machine incorporates the latest servo motor technology that provides the ultimate in reliability. This technology also greatly reduces moving parts and maintenance. These features coupled with Polychem's XL strap coils

add up to a lower overall cost of ownership versus other strapping systems.

The PC PRO is a full featured machine with a basic machine price. The multi color touchscreen



controls with diagnostics and four tier LED status light provide an informative, user friendly design. The quick adjust casters and variable speed conveyor allow for a quick and easy installation.



Dimensions

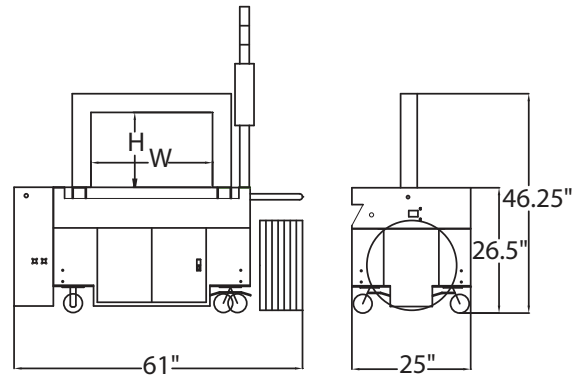

PC PRO		WIDTH	
		25	33
HEIGHT	16		
	23		
	31		
	48		

Shaded Area: Stocked arch sizes

Save time and money with Polychem XL Strap

- MAS51XL - 5mm x 28,000'
- MAS60XL - 6mm x 29,000'
- MAS91XL - 9mm x 16,000'

Standard Features

- Full color touch screen controls with diagnostics and efficiency log
- Four tier LED status light tower
- Variable speed conveyor belts
- Automatic waist high loading
- Quick adjust legs 26" to 35"
- Up/down stream interlocks
- Yaskawa AC servo motors and drives

- Options**
- Soft press for compression

Ideal for...



Boxes/Cartons



Cut size paper



Totes

Specifications

Cycle Rate:	Up to 60 straps per minute depending on arch and package size
Package Weight:	Up to 100 lbs.
Strap Tension:	Up to 100 lbs.
Polypropylene Strap:	5mm, 6mm, 7mm, 9mm, 1/4, 3/8
Electrical Requirements:	208 ~ 480 Volt 3 Phase
Shipping Weight:	650 lbs.



6277 HEISLEY ROAD
MENTOR, OHIO 44060
(440) 357-1500
FAX (440) 352-9553

WEST COAST DISTRIBUTION CENTER
11920 ALTAMAR PLACE
SANTA FE SPRINGS, CA 90670
(562) 903-4579
FAX (562) 903-4579
1-800-899-0822

CALL TOLL FREE 1-800-548-9557
www.polychem.com

