

PHZU

POLYCHEM[®]
PLASTIC STRAPPING SYSTEMS

AUTOMATIC STRAPPING MACHINE

***Save Up To
70%
of Packaging
Weight by
Replacing
Stretch Wrap***



- ***Horizontal Unitizer***
- ***Side Compression***
- ***High Tension Strapping Head***

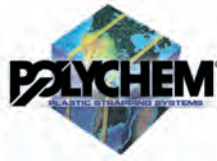

PHZU Horizontal Unitizer Strapping Machine

Polychem's standard horizontal unitizer machine can be customized to meet your specific packing needs. They provide the same reliability and robust construction of the larger machines. These machines can be integrated with powered conveyors for fully automatic processes or they can be coupled with gravity conveyor for semi-automatic processes. Horizontal Unitizer works great on pavers, glass, bottles, crates (tomato, cheese) and many other applications.

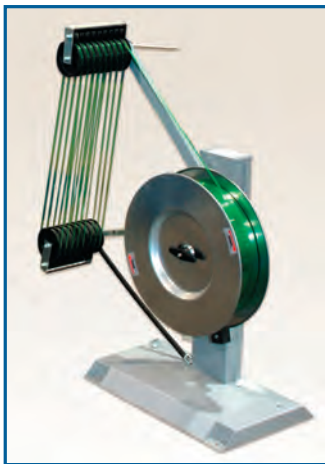

Dispenser



Control box

Dimensions

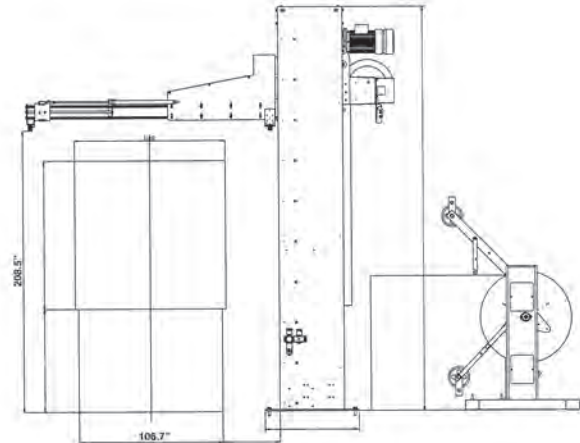

Note: Dimensions may vary based on applications.

OMS HEAD CHOICES

TECHNICAL SPECIFICATIONS	TR14	TR14HD	TR18	TR19HT
Strap Type	PP-PET	PP-PET	PET	PET
Strap Width	from .37" to .62"		from .50" to .75"	from .50" to .75"
Strap Thickness	from .019" to .030"		from .030" to .050"	from .030" to .050"
Maximum Pack Tensioning	400 lbs.		900 lbs	1500 lbs
Continuous Use Tensioning	200 lbs.	400 lbs.	600 lbs	1500 lbs
Utilization Temperature	32° - 120°F			
Noise Level	70 Db			

Optional Features

- Side squaring with pneumatic cylinder
- Infeed conveyor
- Outfeed conveyor
- Spare head
- Fully operational test stand
- Touch screen operator interface panel
- PLC modem connection

Specifications

- Allen Bradley PLC
- 480 VAC/3 phase, 60Hz, 20 Amp service required
- TR strapping head of your choice: TR14, TR14HD, TR18, or TR19HT
- Electric operation
- Uses both polypropylene and polyester



CALL TOLL FREE 1-888-POLYCHEM
www.polychem.com

6277 HEISLEY ROAD
MENTOR, OHIO 44060
(440) 357-1500
FAX (440) 352-9553

or 1-888-765-9243

WEST COAST DISTRIBUTION CENTER
11920 ALTAMAR PLACE
SANTA FE SPRINGS, CA 90670
(562) 903-4579
FAX (562) 903-4579
1-800-899-0822

POLYCHEM OMS SYSTEMS
6277 HEISLEY ROAD
MENTOR, OHIO 44060
(440) 357-1500
FAX (440) 352-9553

