

PBSU

POLYCHEM[®]
PLASTIC STRAPPING SYSTEMS

AUTOMATIC STRAPPING MACHINE

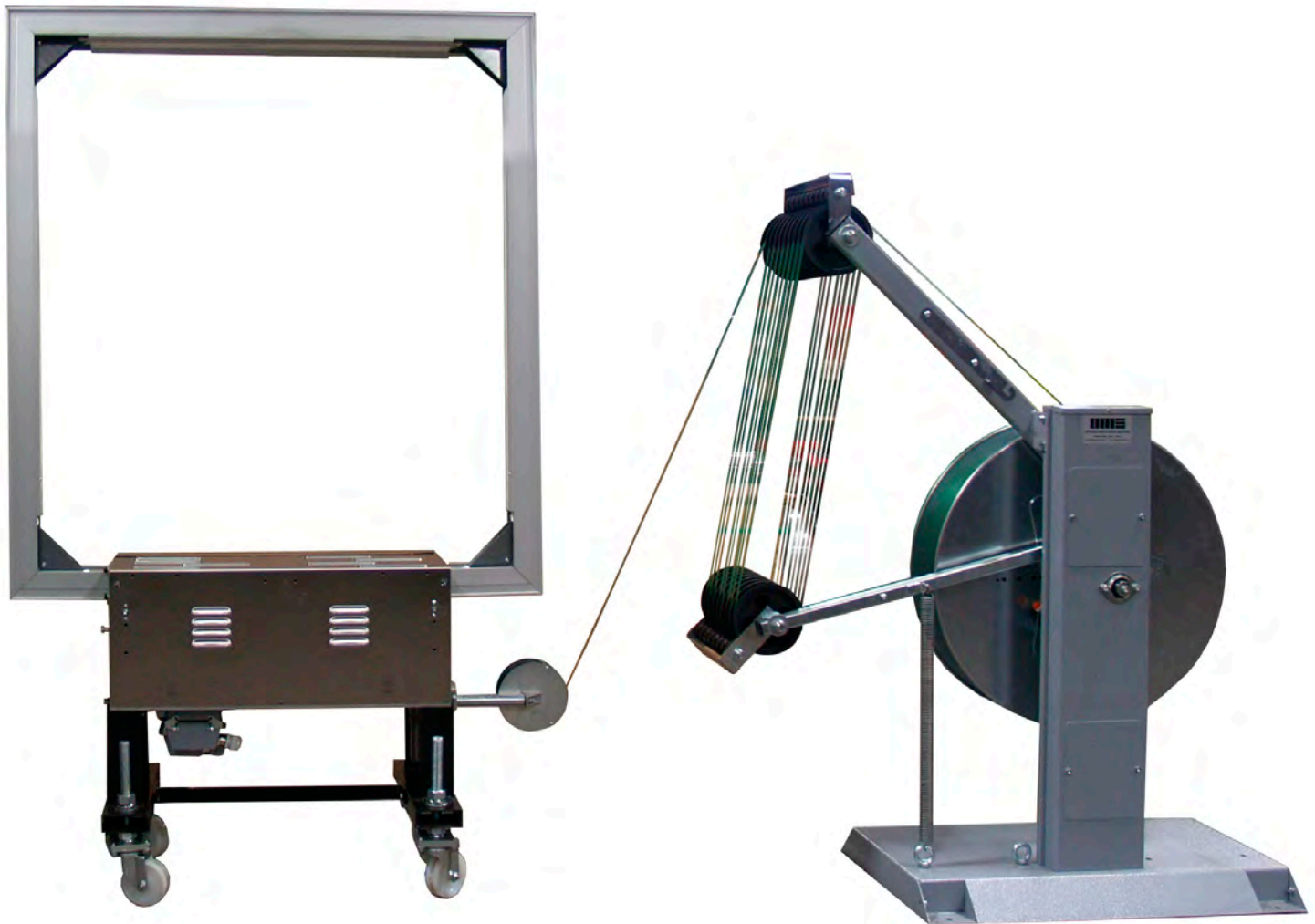

- ***Bottom Seal***
- ***High Tension Strapping Head***
- ***Simple Design, Robust Construction***



PBSU Bottom Seal Automatic Strapping Machine

Polychem's standard bottom seal machine can be customized to meet your specific packing needs. They provide the same reliability and robust construction of the larger machines. These machines can be integrated with powered conveyors for fully automatic processes or they can be coupled with gravity conveyor for semi-automatic processes. Polychem's bottom seal machines are used in applications that require the package height to be fairly low or may vary in height. They are less expensive than top seal machines.



Electrical Control Panel

Options

- Infeed conveyor
- Outfeed conveyor
- Spare head
- Fully operational test stand
- Touch screen operator interface panel
- PLC modem connection

Dimensions

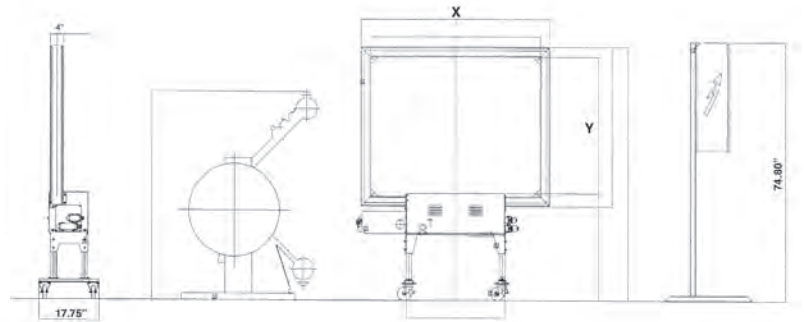

Note: Dimensions X and Y will vary based upon applications.

OMS HEAD CHOICES

| TECHNICAL SPECIFICATIONS | TR14 | TR14HD | TR18 | TR19HT |
|---------------------------|---------------------|----------|---------------------|---------------------|
| Strap Type | PP-PET | PP-PET | PET | PET |
| Strap Width | from .37" to .62" | | from .50" to .75" | from .50" to .75" |
| Strap Thickness | from .019" to .030" | | from .030" to .050" | from .030" to .050" |
| Maximum Pack Tensioning | 400 lbs. | | 900 lbs | 1500 lbs |
| Continuous Use Tensioning | 200 lbs. | 400 lbs. | 600 lbs | 1500 lbs |
| Utilization Temperature | 32° - 120°F | | | |
| Noise Level | 70 Db | | | |

Specifications

- Allen-Bradley PLC
- 480 VAC/3 phase, 60 Hz, 15 Amp service required
- TR strapping head of your choice: TR14, TR14HD, TR18, or TR19HT
- Custom arch sizes to fit your product
- Automatic heater blade cleaning cycle (TR14HD, TR18, TR19HT)
- Aluminum extruded strap track
- Seals are made on the bottom



6277 HEISLEY ROAD
MENTOR, OHIO 44060
(440) 357-1500
FAX (440) 352-9553

WEST COAST DISTRIBUTION CENTER
11920 ALTAMAR PLACE
SANTA FE SPRINGS, CA 90670
(562) 903-4579
FAX (562) 903-4579
1-800-899-0822

POLYCHEM OMS SYSTEMS
6277 HEISLEY ROAD
MENTOR, OHIO 44060
(440) 357-1500
FAX (440) 352-9553



CALL TOLL FREE 1-888-POLYCHEM
www.polychem.com

or 1-888-765-9243