

SV5000S

POLYCHEM[®]
PLASTIC STRAPPING SYSTEMS

AUTOMATIC STRAPPING MACHINE

***UP TO
50
STRAPS PER
MINUTE!***



- ***Side Seal Configuration***
- ***Servo Technology Provides Ultimate Reliability***
- ***Loop Eject and End of Strap Eject***



SV5000S Automatic Strapping Machine

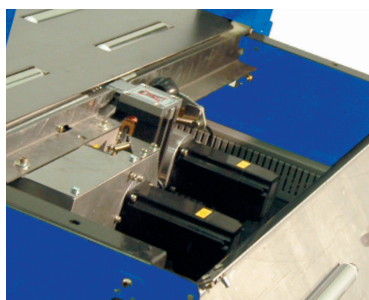

The SV5000S Automatic Strapping Machine incorporates the latest Servo motor technology that provides the ultimate in reliability. This technology also greatly reduces moving parts and maintenance coupled with

Polychem's XL Strap coils add up to lower overall cost of ownership of any other strapping system. Its the same reliable SV-5000 strapping head in a side seal configuration. The side mounting prevents debris from contaminating the seal head.

Dimensions

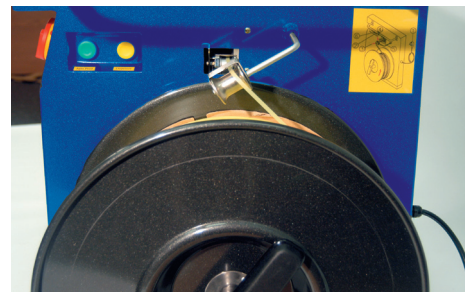
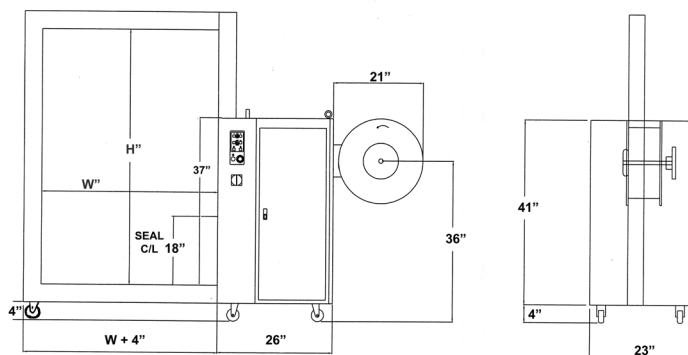

Push Button Auto Load

**Call 1.800.548.9557
for available arch sizes**



Control Panel

Standard Features

- Capable up to 50 straps/minute
- PLC controlled with diagnostics
- Electronic reel brake
- Electronic tensioning
- Movable magnetic pendant
- Loop ejector
- Long life heater blade
- Power saving system, motor runs only during cycle
- Easy access strap path (no tools)
- Auto refeed
- Choice of arch sizes and strap widths
- Movable foot pedal activates machine

Specifications

Minimum Package Size:	4" x 4"
Maximum Package Size:	Within arch size
Maximum Tension:	150 lbs.
Electrical Supply:	110 VAC, 15A
Core Sizes:	8"x8" or 9"x8"
Strap Sizes:	1/4", 3/8" polypropylene Metric: 5, 6, 7, 9mm polypropylene
Weight:	480 lbs.

NOTE: All throughput estimations vary with actual size, package size, and conveyor speed.



CALL TOLL FREE 1-888-POLYCHEM
www.polychem.com

6277 HEISLEY ROAD
MENTOR, OHIO 44060
(440) 357-1500
FAX (440) 352-9553

or 1-888-765-9243

WEST COAST DISTRIBUTION CENTER
11920 ALTAMAR PLACE
SANTA FE SPRINGS, CA 90670
(562) 903-4579
FAX (562) 903-4579
1-800-899-0822

EVERGREEN PLASTICS FACILITY
202 WATERTOWER DRIVE
CLYDE, OH 43410
(419) 547-1400
FAX (419) 547-4551