

PC600AL

POLYCHEM[®]
PLASTIC STRAPPING SYSTEMS

AUTOMATIC STRAPPING MACHINE

***UP TO
25
STRAPS PER
MINUTE!***



- ***An Economy Priced Machine***
- ***Push Button Auto-Strap Loading***
- ***Loop Ejector***



PC600AL Automatic Strapping Machine

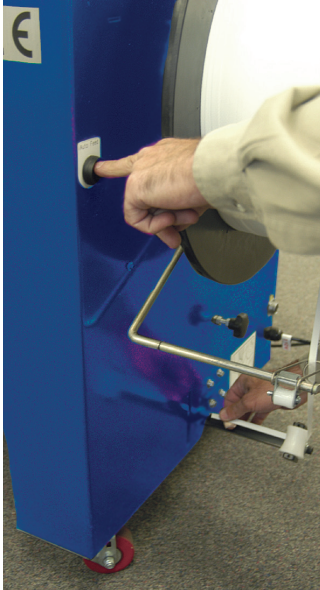

Push Button Auto Load

The Polychem PC600AL is an economical strapping machine that offers many features found on more expensive units. It is capable of 25 straps per minute to meet the production requirements of medium volume applications. Simple, reliable, centralized controls make it operator friendly.

Dimensions

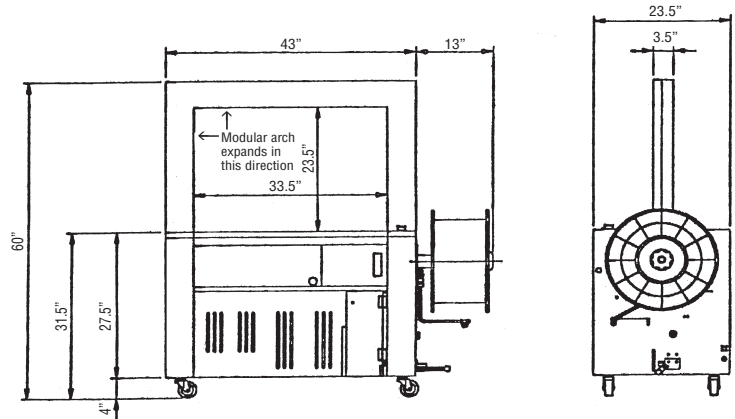

Standard Features

- Lubrication free sealing mechanism
- Cycle Start Standard Options –foot switch, push button or table top ball switch
- Capable of up to 25 straps per minute
- Simple, centralized controls
- Portable, on casters
- Available in 3/8" (9mm) & 1/2" (12mm) strap on 8x8 or 9x8 core size
- Table Height = 31 1/2"
- Hinged, easily removable stainless steel table top with rollers, standard
- Automatic re-feed mechanism
- Weld-Cool switch for highly compressible packages or very rigid packages that need high tension
- Automatic strap loading
- Loop ejector to eject accidentally actuated straps

PC600AL		WIDTH		
		25	33	41
HEIGHT	23			
	31			
	39			

Shaded Area: Stocked arch sizes
Non-Shaded Area are on a 12 week Special Order Basis

Specifications

- Minimum Package Size:** 6 inches wide x 2 inches high
- Maximum Package Size:** within arch size
- Maximum Tension:** 180 lbs.
- Speed:** 2.5 seconds/cycle
- Electrical Supply:** 110 VAC – Standard
- Core Sizes:** 8"x8" or 9"x8"
- Strap Sizes:** 3/8" & 1/2" P.P. (9mm & 12mm)



CALL TOLL FREE 1-888-POLYCHEM
www.polychem.com

6277 HEISLEY ROAD
MENTOR, OHIO 44060
(440) 357-1500
FAX (440) 352-9553

or 1-888-765-9243

WEST COAST DISTRIBUTION CENTER
11920 ALTAMAR PLACE
SANTA FE SPRINGS, CA 90670
(562) 903-4579
FAX (562) 903-4579
1-800-899-0822

POLYCHEM OMS SYSTEMS
6277 HEISLEY ROAD
MENTOR, OHIO 44060
(440) 357-1500
FAX (440) 352-9553

