

PC1000ST

POLYCHEM[®]
PLASTIC STRAPPING SYSTEMS

AUTOMATIC STRAPPING MACHINE

***Stainless Steel
for Harsh
Environments
up to
65
Straps
per minute***

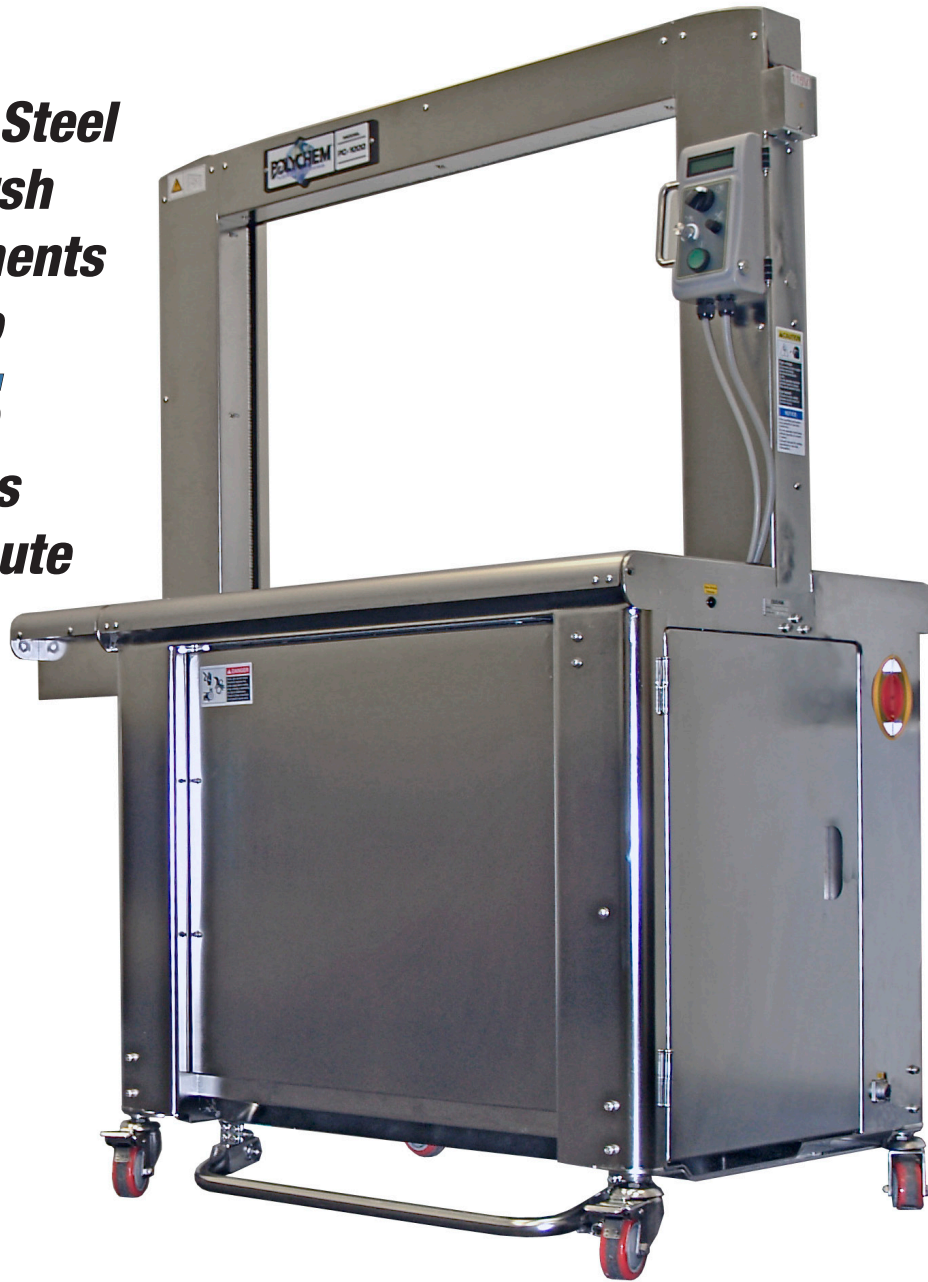

- ***For the Food Industry: poultry, meat, fish, etc.***
- ***High Speed Reliability***
- ***Easy to operate***



PC1000ST Stainless Steel Automatic Strapping Machine

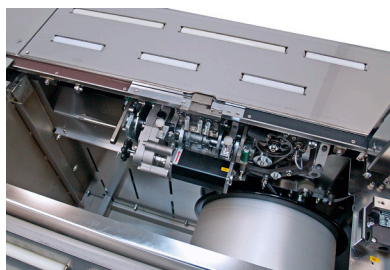

The PC1000ST is an all stainless steel innovative high speed automatic strapping machine. It is equipped with all industry standard features. The PC1000ST offers optimal performance, high cycle speed and easy maintenance. This machine is the most cost effective solution to your strapping requirements in its class today.

Waist high quick change coil and strap feed. Coil retracts back into cabinet.



Dimensions

PC 1000ST

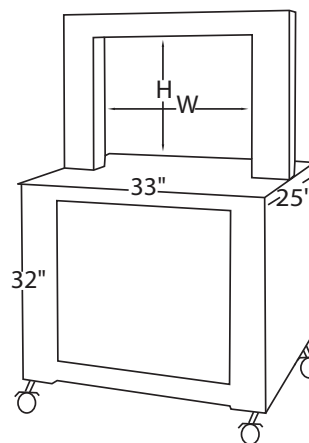

Call 1.800.548.9557 for available arch sizes

Standard Features

- All SUS 304 Stainless Steel
- Cycle speed is up to 65 straps per minute (depending on arch size)
- German DC brushless motor technology
- No belts, clutches, or pulleys. 30% fewer parts, less maintenance and items to go wrong
- Waist high quick change coil and strap feed
- Easy access operating control panel
- Easy access strap chute-no tools required
- Front foot-bar pedal plus movable foot switch
- One piece strap chute
- Sensor controlled heater
- End of coil strap ejector/loop ejector
- Electronic brake / Auto loader
- Adjustable table height from 32" to 36"
- Lockable casters
- Choice of 2 arch sizes, others are special order
- Roller top standard on arches 33" wide or wider



Easy access control panel.

Save time and money with Polychem XL Strap

- MAS50XL - 5mm x 30,000'
- MAS60XL - 6mm x 29,000'
- MAS90XL - 9mm x 18,000'

Specifications

Cycle Rate:	Up to 65 straps per minute depending on arch and package size
Package Weight:	Up to 100 lbs.
Strap Tension:	Up to 100 lbs.
Polypropylene Strap:	5mm, 6mm, 9mm, 3/8"
Electrical Requirements:	110V 60Hz 1 Phase
Shipping Weight:	450 lbs.

NOTE: All throughput estimations vary with actual size, package size, and conveyor speed.



CALL TOLL FREE 1-888-POLYCHEM
www.polychem.com

6277 HEISLEY ROAD
 MENTOR, OHIO 44060
 (440) 357-1500
 FAX (440) 352-9553

or 1-888-765-9243

WEST COAST DISTRIBUTION CENTER
 11920 ALTAMAR PLACE
 SANTA FE SPRINGS, CA 90670
 (562) 903-4579
 FAX (562) 903-4579
 1-800-899-0822



POLYCHEM OMS SYSTEMS
 6277 HEISLEY ROAD
 MENTOR, OHIO 44060
 (440) 357-1500
 FAX (440) 352-9553